

Note: The drawing sizes may be different from the indicated sizes, so don't make actual measurement of the drawing shape.

Plant section	Japan
Foreign countries	()
()	()
Not yet decided	()
Number of mold drive	
Weight	

20	
19	
18	
17	Approval
16	
15	
14	Drawing inspection
13	
12	
11	
10	
9	Designing
8	
7	
6	Working out drawing
5	
4	Our used early model
3	
2	Issuing of drawing
1	

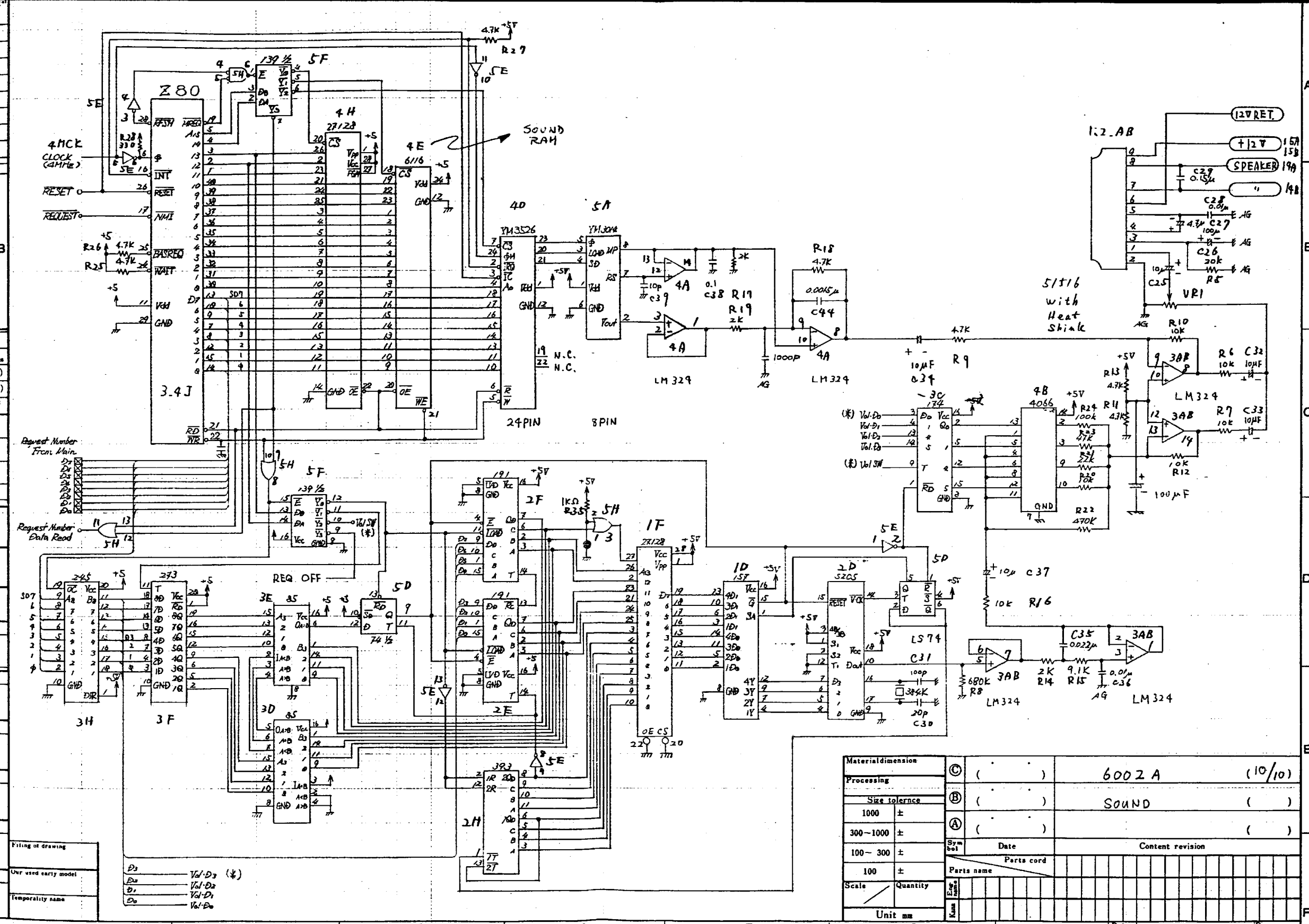

Material dimension	()	6002 A	(10/10)
Processing	()	SOUND	()
Size tolerance	()		()
1000 ±	()		()
300-1000 ±	()		()
100-300 ±	()		()
100 ±	()		()
Scale	Quantity	Parts name	Content revision
Unit mm			