

JALECO

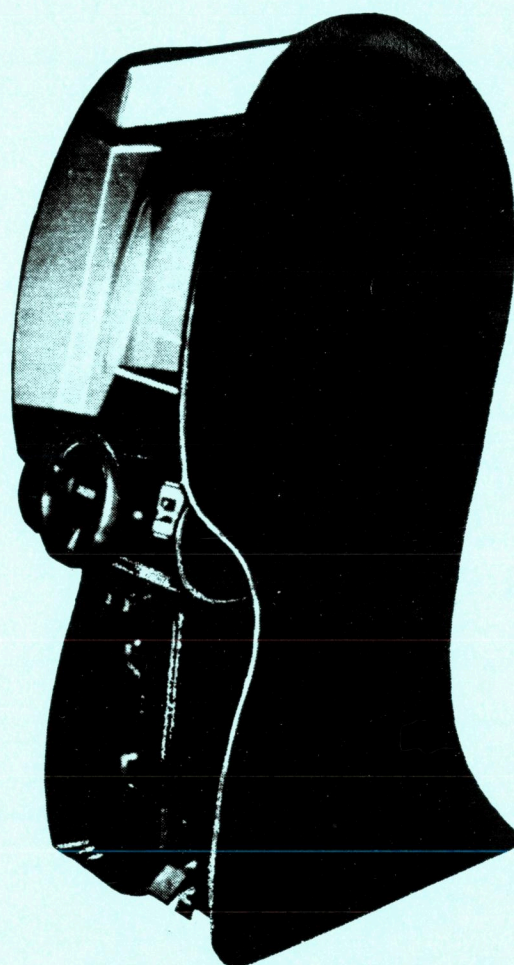

INSTRUCTION MANUAL

WORLD CHAMPIONSHIP
**RAT-1 SUPER
BATTLE**



MANUAL NO. MT-00-00051-0

Warnings

Installation

- This machine is for use indoors. The following locations are not suitable.
 - Outdoors
 - In places where there is exposure to rain, leaks, or direct sunlight. In addition, damp or humid places, dusty places or near a heat source. Places of high temperature or places where the formation of dew is possible.
 - To ensure safety, before operation, this machine must be placed in a location with an emergency exit, and a fire extinguisher must be nearby.
 - This machine must not be placed on an unstable surface. In addition, any incline or any other surface which is not flat cannot be used.
 - This machine must not be placed near dangerous, inflammable materials or volatile chemicals.
 - The 4 leg levelers should be adjusted to raise the casters 2-5mm (1/8inch).

Transportation

- Please take care during transportation so that no excessive shocks are incurred by the machine. Also, make sure the seat unit is removed from the machine.
 - ◆ **ATTENTION** : Make sure to disassemble the seat units for transportation

Operation

- Power source should be 117V AC.
- Make sure to connect a ground wire with the ground terminal during setup.
- Since parts of the monitor may hold high voltage, pay adequate attention during troubleshooting and adjusting.
- When disconnecting the power cord, please be sure to pull the plug and not the power cord.
- Make sure the power is off before exchanging components, or connecting / disconnecting connectors.
- Use specified fuses only.
- When P.C.B.'s are checked by a tester or similar devices, the P.C.B.'s may be damaged due to internal tester voltages.
- When only 1 machine is in use, make sure that both communication connector panel switches are set to "DUMMY-ON".

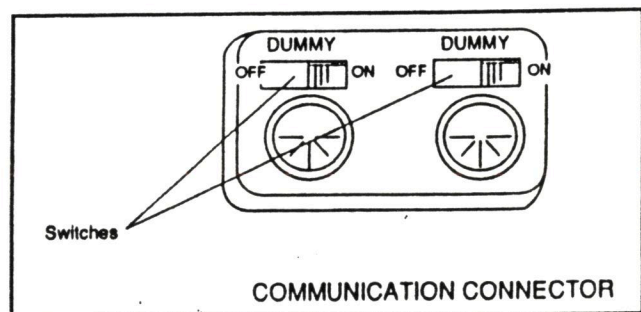

Cable Connection

○When 2 to 4 machines are linked together, communication cables are needed for the link.

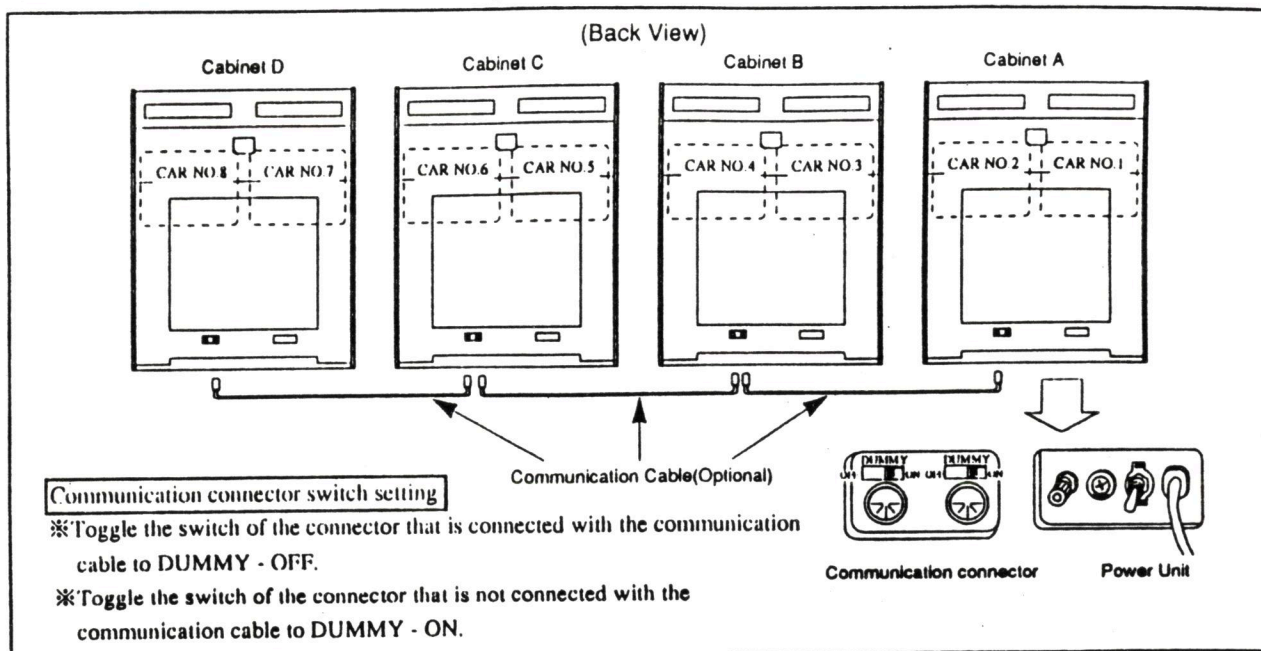

ATTENTION: Avoid placing communication cables near other wiring.

Adjustments

Control Panel

○The adjustment switches are located inside the coin entry door (see diagram). The switches on the right side are for the right player and the switches on the left side are for the left player.

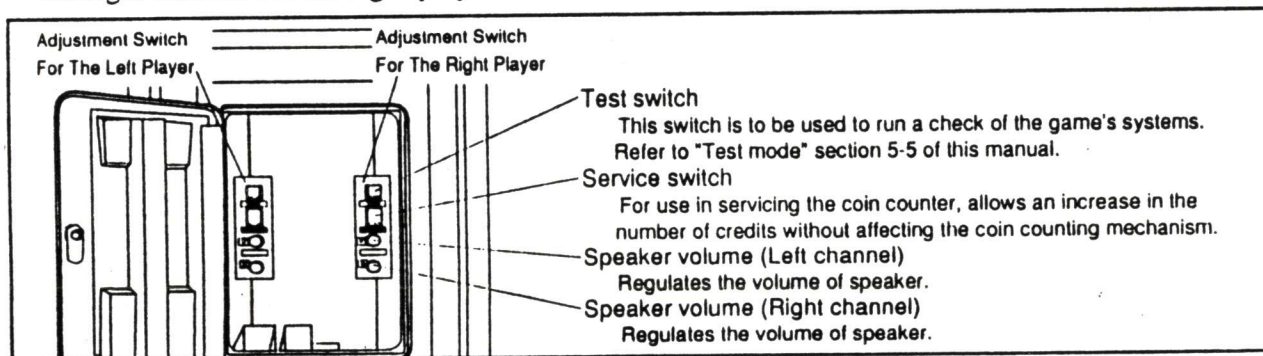

Monitor Adjustments

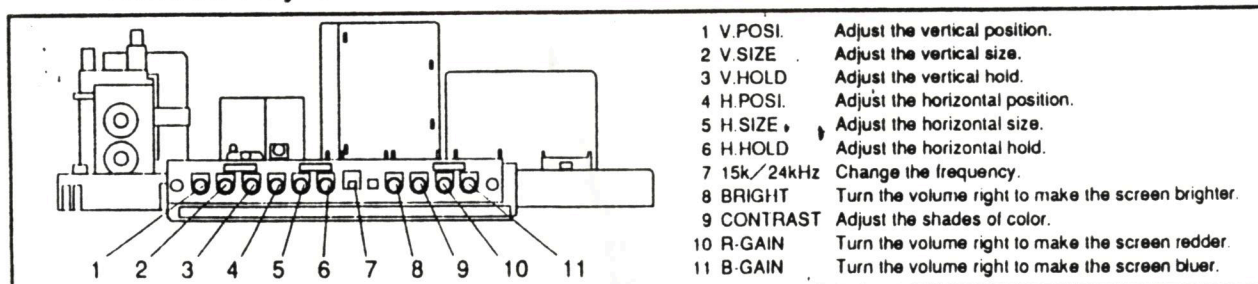

Dip Switch Settings

- Open the rear cabinet door, As illustrated below. You will find the 2 main printed circuit boards - - One for the left side, And one for the right side. The dip switches are located on these 2 boards (3 dip switches on the front side, 1 on the back side).

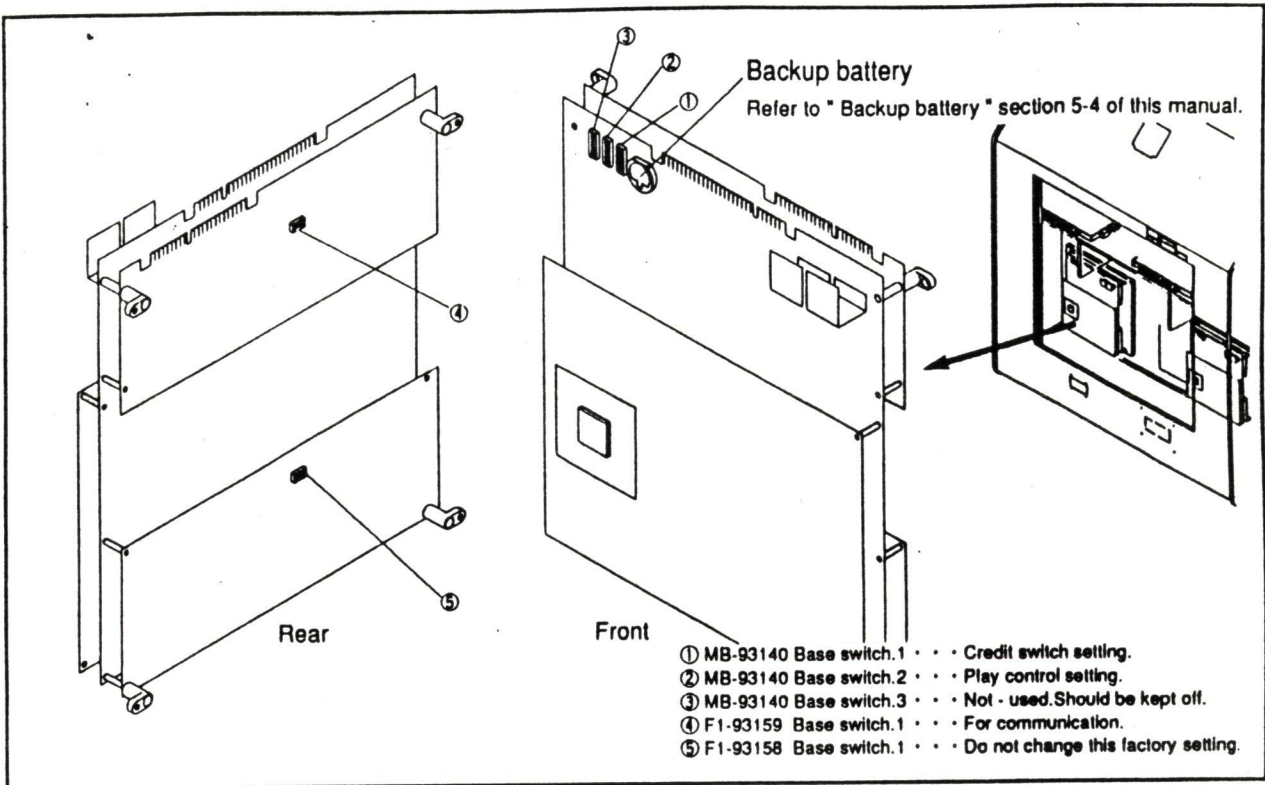

① MB-93140 Base switch 1 . . . Credit switch setting.

- In link play, Credit changes should be made for all coin chutes (1).

U.S.A. / Taiwan

DIP SWITCH No.1		1	2	3	4	5	6	7	8
COIN CHUTE (1)	1COIN/1CREDIT	OFF	OFF	OFF					
	1COIN/2CREDITS	ON	OFF	OFF					
	1COIN/3CREDITS	OFF	ON	OFF					
	1COIN/4CREDITS	ON	ON	OFF					
	2COIN/1CREDIT	OFF	OFF	ON					
	3COIN/1CREDIT	ON	OFF	ON					
	4COIN/1CREDIT	OFF	ON	ON					
	FREE PLAY	ON	ON	ON					
COIN CHUTE (2)	1COIN/1CREDIT				OFF	OFF	OFF		
	1COIN/2CREDITS				ON	OFF	OFF		
	1COIN/3CREDITS				OFF	ON	OFF		
	1COIN/4CREDITS				ON	ON	OFF		
	2COIN/1CREDIT				OFF	OFF	ON		
	3COIN/1CREDIT				ON	OFF	ON		
	4COIN/1CREDIT				OFF	ON	ON		
	FREE PLAY				ON	ON	ON		
NOT USED - KEEP SWITCH TO "OFF"								OFF	OFF

* Factory settings for all these are "off".

F-1 SUPER BATTLE

DIP SWITCH ADJUSTMENT

MB-93140 PCB DIP SW 2		1	2	3	4	5	6	7	8
PLAY PRICE SETTING	USA	OFF	ON						
	EUROPE	ON	OFF						
DIFFICULTY LEVEL	NORMAL			OFF	OFF				
	DIFFICULT			ON	OFF				
	HARD			OFF	ON				
	EASY			ON	ON				
TIME UP MODE	YES					OFF			
	NO					ON			
SOUND DURING DEMO	ON						OFF		
	OFF						ON		
SPEED METER DISPLAY	Km/h							OFF	
	mph							ON	
CREDIT COUNTER	DISPLAY EREMITE								OFF ON

F1-93159 PCB DIP SW 1		1	2	3	4
MASTER CAR		ON			
	OTHER CAR	OFF			
CAR NUMBER	1		ON	ON	ON
	2		OFF	ON	ON
	3		ON	OFF	ON
	4		OFF	OFF	ON
	5		ON	ON	OFF
	6		OFF	ON	OFF
	7		ON	OFF	OFF
	8		OFF	OFF	OFF

FOLLOWING SETTINGS ARE ONLY AVAILABLE WHEN MB-93140 DIP SW 2-1 'OFF' AND SW 2-2 'ON'

MB-93140 PCB DIP SW 1		1	2	3	4	5	6	7	8
COIN CHUTE 1	1 COIN 1 CREDIT	OFF	OFF	OFF					
	1 COIN 2 CREDITS	ON	OFF	OFF					
	1 COIN 3 CREDITS	OFF	ON	OFF					
	1 COIN 4 CREDITS	ON	ON	OFF					
	2 COIN 1 CREDITS	OFF	OFF	ON					
	3 COINS 1 CREDIT	ON	OFF	ON					
	4 COINS 1 CREDIT	OFF	ON	ON					
FREE PLAY	ON	ON	ON						
COIN CHUTE 2	1 COIN 1 CREDIT				OFF	OFF	OFF		
	1 COIN 2 CREDITS				ON	OFF	OFF		
	1 COIN 3 CREDITS				OFF	ON	OFF		
	1 COIN 4 CREDITS				ON	ON	OFF		
	2 COIN 1 CREDITS				OFF	OFF	ON		
	3 COINS 1 CREDIT				ON	OFF	ON		
	4 COINS 1 CREDIT				OFF	ON	ON		
FREE PLAY				ON	ON	ON			
KEEP SWITCH TO 'OFF'								OFF	OFF

FOLLOWING SETTINGS ARE ONLY AVAILABLE WHEN MB-93140 DIP SW 2-1 'ON' AND SW 2-2 'OFF'

MB-93140 PCB DIP SW 1		1	2	3	4	5	6	7	8
COIN CHUTE 1	1 COIN 1 CREDIT	OFF	OFF	OFF					
	1 COIN 2 CREDITS	ON	OFF	OFF					
	1 COIN 3 CREDITS	OFF	ON	OFF					
	1 COIN 4 CREDITS	ON	ON	OFF					
	1 COIN 5 CREDITS	OFF	OFF	ON					
	1 COIN 6 CREDITS	ON	OFF	ON					
	1 COIN 7 CREDITS	OFF	ON	ON					
	2 COINS 3 CREDITS	ON	ON	ON					
COIN CHUTE 2	1 COIN 1 CREDIT				OFF	OFF	OFF		
	1 COIN 2 CREDITS				ON	OFF	OFF		
	1 COIN 3 CREDITS				OFF	ON	OFF		
	1 COIN 4 CREDITS				ON	ON	OFF		
	1 COIN 5 CREDITS				OFF	OFF	ON		
	1 COIN 6 CREDITS				ON	OFF	ON		
	1 COIN 7 CREDITS				OFF	ON	ON		
2 COINS 3 CREDITS									
FREE PLAY	NO							OFF	
	YES							ON	
KEEP SWITCH TO 'OFF'									OFF

Europe

DIP SWITCH No.1		1	2	3	4	5	6	7	8
COIN CHUTE (1)	1COIN/1CREDIT	OFF	OFF	OFF					
	1COIN/2CREDITS	ON	OFF	OFF					
	1COIN/3CREDITS	OFF	ON	OFF					
	1COIN/4CREDITS	ON	ON	OFF					
	1COIN/5CREDITS	OFF	OFF	ON					
	1COIN/6CREDITS	ON	OFF	ON					
	1COIN/7CREDITS	OFF	ON	ON					
	2COIN/3CREDITS	ON	ON	ON					
COIN CHUTE (2)	1COIN/1CREDIT				OFF	OFF	OFF		
	1COIN/2CREDITS				ON	OFF	OFF		
	1COIN/3CREDITS				OFF	ON	OFF		
	1COIN/4CREDITS				ON	ON	OFF		
	1COIN/5CREDITS				OFF	OFF	ON		
	1COIN/6CREDITS				ON	OFF	ON		
	1COIN/7CREDITS				OFF	ON	ON		
	2COIN/3CREDITS				ON	ON	ON		
FREE PLAY	ON							OFF	
	OFF							ON	
NOT USED - KEEP SWITCH TO "OFF"									OFF

* Factory settings for all these are "off".

② MB-93140 Base switch 2 . . . Play control setting.

U.S.A. / Taiwan

DIP SWITCH No.2		1	2	3	4	5	6	7	8
NOT USED		OFF	ON						
DIFFICULTY LEVEL	NORMAL			OFF	OFF				
	HARD			ON	OFF				
	HARDEST			OFF	ON				
	EASY			ON	ON				
NOT USED - KEEP SWITCH TO "OFF"						OFF			
SOUND IN ATTRACT MODE "ON"							OFF		
							ON		
NOT USED - KEEP SWITCH TO "OFF"								OFF	OFF

Europe

DIP SWITCH No.2		1	2	3	4	5	6	7	8
NOT USED		ON	OFF						
DIFFICULTY LEVEL	NORMAL			OFF	OFF				
	HARD			ON	OFF				
	HARDEST			OFF	ON				
	EASY			ON	ON				
NOT USED - KEEP SWITCH TO "OFF"						OFF			
SOUND IN ATTRACT MODE "ON"							OFF		
							ON		
NOT USED - KEEP SWITCH TO "OFF"								OFF	OFF

③ MB-93140 Base switch3 . . . Not - used. Should be kept off.

④ F1-93159 Base switch1 . . . For communication.

- In link play, Car No. 1 serves as the master. Hence, Set DIP switch # 1 off for all other cars.
- In single play, Make sure to set switch # 1 on.
- Change dip switch 2 - 4, (car No.) to change the types of cars.

DIP SWITCH No.4		1	2	3	4
MASTER		ON			
SO FORTH		OFF			
CABINET	No.1		ON	ON	ON
	No.2		OFF	ON	ON
	No.3		ON	OFF	ON
	No.4		OFF	OFF	ON
	No.5		ON	ON	OFF
	No.6		OFF	ON	OFF
	No.7		ON	OFF	OFF
	No.8		OFF	OFF	OFF

* NOT USED - KEEP SWITCH TO "OFF"

⑤ F1-93158 Base switch.1 . . . Do not change this factory setting.

Backup Battery

- Use lithium battery (CR - 2032, Not included) for data backups.
- No data backups are possible without batteries.
- Change the battery every 3 months to ensure the integrity of backed up data.
- Always dispose of a drained battery, Since letting it remain in the machine will cause mechanical problems.

Test Mode

- Running the following tests will confirm that your machine is working correctly. These tests will assure you that the wiring and switches are correctly adjusted. In addition, the monitor's screen color and the sound adjustment can be checked.

1. Test Types

- To bring up the screen shown on the right, Open the coin door, Then press the test switch. You are now ready to test each item listed on the screen.
- Use the start button to move the arrow. Step on the pedal to test the item pointed to by the arrow.
- Press the test button again to return to the game screen.

→ROM RAM
 CROSS HATCH
 COLOR BAR
 I/O CHECK
 DIP SW.
 SOUND CHECK
 COMMUNICATION
 BOOK KEEPING

 EXIT→TEST SW.

- ROM / RAM Checks the ROMs and RAMs on the board.
- CROSS HATCH A test pattern display for monitor adjustment.
- COLOR BAR A color bar display for color adjustment.
- I / O Checks the switches, lamps, potentiometer, etc.
- DIP SW Shows the current DIP switch settings.
- SOUND Checks the sound ROM / RAM and the speaker.
- COMMUNICATION Checks the like system.
- BOOK KEEPING Displays income, Play time and other Book - Keeping data.

2. Test Mode Screen Headings

1) ROM / RAM CHECK

- The following screen will be displayed when the ROM/RAM check is selected. If the ROM / RAM are functioning correctly, "OK" will be displayed. If there is a fault on the ROM / RAM, "NG" will be displayed.

ROM RAM CHECK	
MAIN	
VRAM	OK
SCRATCH RAM	OK
COLOR RAM	OK
OBJECT RAM	OK
PROGRAM ROM	OK
EXIT→TEST SW.	

2) CROSS MATCH CHECK

- Displays test patterns for monitor adjustment. Adjust the monitor until the red lines fill the entire screen.

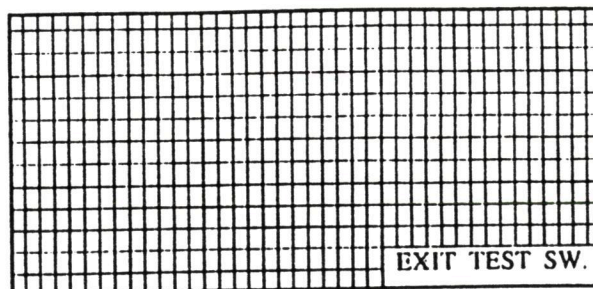

3) COLOR BAR CHECK

- This screen will be displayed for the color bar check.

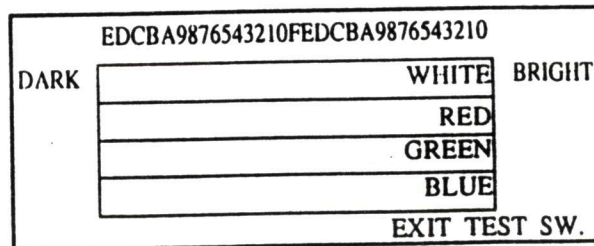

4) I/O CHECK

- Checks the switches, lamps, and potentiometers.
- When the "Start" button is pressed, the lamps will go on and "ON" will be displayed if normal.
- When the "Shift" is set on high, "ON" will be displayed if normal.
- When the other switches are pushed, "ON" will be displayed if normal.
- When the accelerator is not pressed, the normal reading is 80 ± 10 .
- Press the start switch. If the lamp lights up, And "ON" is displayed on the screen, The switch is functioning normally.
- Press the test switch again. The screen now is ready to test steering shock, Seat motor and 7 - segment led.
- Use the start button to move the arrow. Step on the pedal to test the item pointed to by the arrow.

I/O CHECK				
CAR No.1				
START	SW.	ON	COIN 1	SW.
SHIFT	SW.		COIN 2	SW.
BRAKE	SW.		ACCELE	80
SERVICE	SW.		HANDLE	80
EXIT→TEST SW.				

*The above display appears when you execute the test in car seat No. 1.

I/O CHECK
→STEERING SHOCK
SEAT MOTOR
7 SEG. CHECK
EXIT

5) DIP SWITCH CHECK (only "ON" will be displayed)

· This screen will show for the DIP switch check.

* The example on the right is for the Japanese market - free play, Master car in link play, Car number is 1, And game level is set at normal.

		DIP SW. CHECK							
		1	2	3	4	5	6	7	8
MB-93140	SW.1	ON	ON	ON					
MB-93140	SW.2								
F1-93159	SW.2	ON	ON	ON	ON	--	--	--	--
NATION		JAPAN							
COIN CHUTE 1		FREE PLAY							
COIN CHUTE 2		1 COIN 1 CREDIT							
LEVEL		NORMAL							
DEMO SOUND		ON							
EXIT→TEST SW.									

6) SOUND CHECK

- Check the back ground music and sound effect.
- Press the start button to move the arrow to different items.
- Select the music number and decide one by stepping on the accelerator.
- When you select the speaker check, The sound runs, First from the left speaker, And then from the right speaker.

SOUND CHECK	
SOUND ROM	OK
SOUND RAM	OK
→BGM REQUEST	00
SE REQUEST	00
SPEAKER CHECK	
EXIT→TEST SW.	

7) COMMUNICATION CHECK

· When the cabinets are connected, it is possible to run a COM - LINK COMMUNICATION CHECK. However, if the other cabinets do not have the "COMMUNICATION CHECK" display on the screen, this test will not run.

* The screen on the right results after car No.1 has been tested and set to master car in link play.

- Normal OK
- Faulty NG
- Not connected NOT CONNECTED
- Power is off NOT CONNECTED
- Not being checked WAITING

COMMUNICATION CHECK		
CAR	1	
COMMUNICATION MASTER		
CAR	2	OK
CAR	3	NOT CONNECTED
CAR	4	WAITING
CAR	5	NG
CAR	6	OK
CAR	7	NOT CONNECTED
CAR	8	WAITING
EXIT→TEST SW.		

8) BOOK KEEPING

- Displays income, Play time and other Book - Keeping data.
- Press the start button to advance to next page (a total of 2 pages).
- The first page contains the data for that day, Containing the cumulative data from the moment the power is switched on to when test mode is entered into. These data will be reset if power is switched off.
- The second page contains the cumulative data. Use a battery (not included) to examine the backed - up cumulative data. (make sure you read section 5 - 4, Backup battery.)
- To reset all data in page 2, Press the test switch while holding down on the start button.
- Press the test switch to return to test mode menu.

One particular day (from power on to entering into test mode)

BOOK KEEPING		
TODAY		
COIN CHUTE 1	00123	
COIN CHUTE 2	00000	
POWER ON	00567MINS.	
ATTRACT MODE	00246MINS.	
	SINGLE	COM.
GAMES PLAYED	00049	00074
TOTAL SINGLE+COM.	00123	
TOTAL PLAY TIME	00127MINS.	00194MINS.
TOTAL SINGLE+COM.	00321MINS.	
AV. GAME (SECS.)	00155SECS.	00158SECS.
TOTAL SINGLE+COM.	00156SECS.	
NEXT→START BUTTON EXIT →TEST SW.		

Total (cumulative)

BOOK KEEPING		
TOTAL		
COIN CHUTE 1	00678	
COIN CHUTE 2	00000	
POWER ON	05678MINS.	
ATTRACT MODE	03456MINS.	
	SINGLE	COM.
GAMES PLAYED	00234	00444
TOTAL SINGLE+COM.	00678	
TOTAL PLAY TIME	00722MINS.	01500MINS.
TOTAL SINGLE+COM.	02222MINS.	
AV. GAME (SECS.)	00185SECS.	00202SECS.
TOTAL SINGLE+COM.	00196SECS.	
RESET→START BUTTON+TEST SW. EXIT →TEST SW.		

• Details of each item

- Coin chute 1 & 2 Number of coins inserted. Coin chute is not frequently used.
- Power on Length of time elapsed since power on. Not including time spent in test mode.
- Attract mode Length of time of game not being played since power on. Not including time spent in test mode.
- Games played Number of games played since power on. Separate accounts for single and link play, Including cumulative accounts.
- Total play time Cumulative play time since power on. separate accounts for single and link play.
- AV. game (SECS.) . . . Average play time per credit.

How to play

- F - 1 Super Battle is a racing game where players control a car which must be driven around a selected circuit.
- Up to 8 players may join the race in the com - link mode. Players may select from three circuits ; France, Belgium or U.S.A.
 - France : An original circuit which runs through the center of Paris.
 - Belgium : Based on the actual F - 1 circuit which runs through the mountains.
 - U.S.A. : An original circuit based in a stadium.
- Insert a coin and the screen display changes to the circuit selection screen. Use the steering wheel to select a circuit and then press the accelerator pedal to confirm your selection. If other players insert a coin before the circuit has been confirmed by the first player then they may join the race. When all players have selected a circuit then and they have pressed the "Star" button, the race begins.
- In the case where each player chooses different courses, the course with the majority will be chosen. However, if there is no majority, the computer will decide the course.
- If check points are reached within given time, Extended time will be given. Otherwise, Game will be over.
- A Player wins if he circles the course 4 times.

Controls

- Accelerator Pedal to speed up your car.
- Brake Slows down your car.
- Steering wheel Turn LEFT / RIGHT to change car direction.
- Shift lever Choose from "Hi" gear and "Low" gear.

Basic Maintenance

Steering Unit

To remove the dash cover assembly, remove the top four bolts and four button bolts. Then remove the two connectors from the steering wheel unit, one connector from the shift lever unit, and one connector from the start switch.

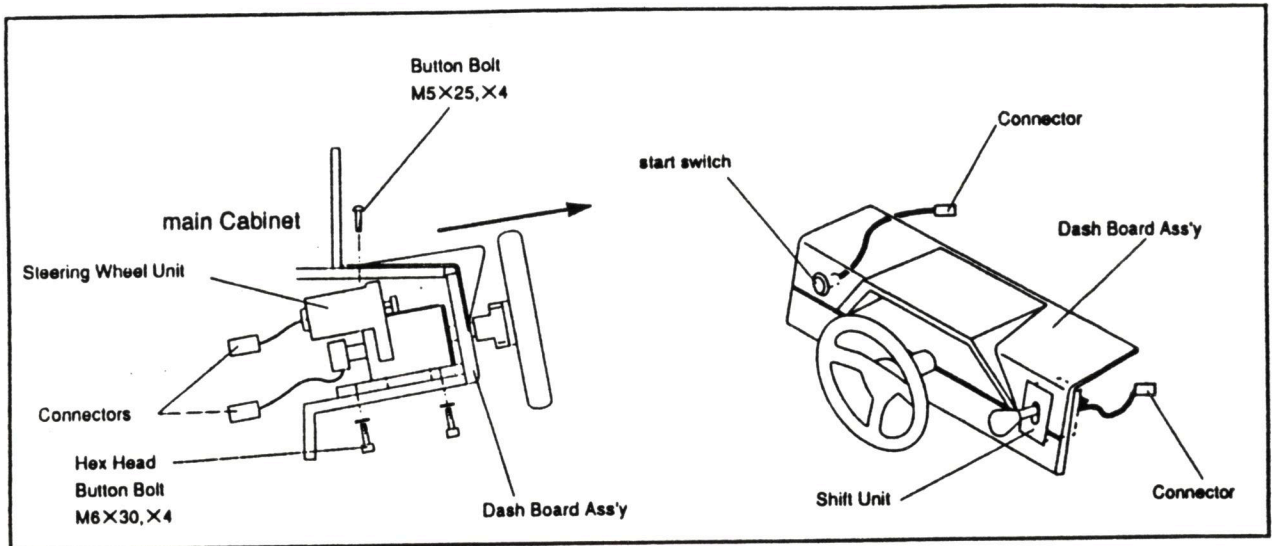

- Remove the steering wheel by taking out the three hex head button bolts in the base.

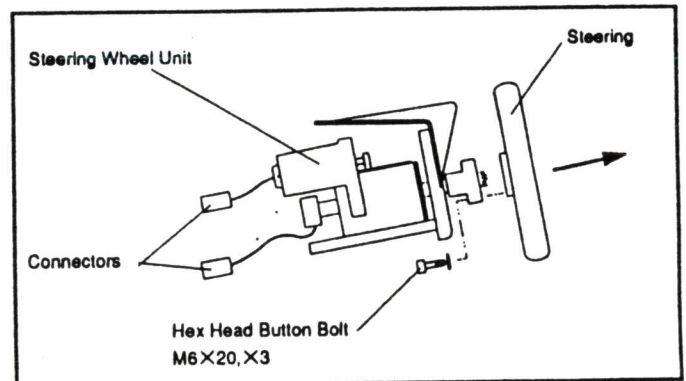

- Remove the "C" stop ring, and remove the wheel holder.
- To remove the steering wheel unit, remove the four bottom bolts. Pull apart the connectors.

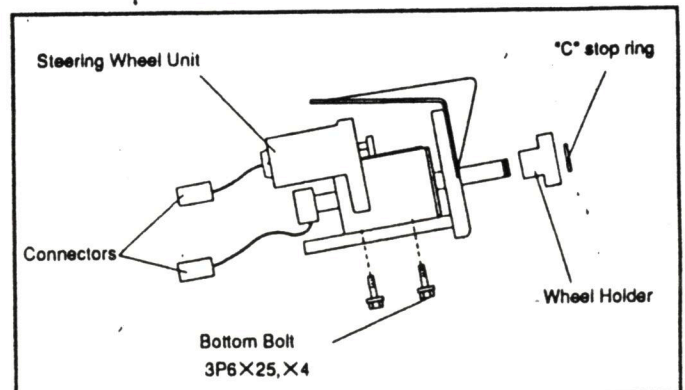

○ Adjusting and changing the potentiometer of the steering wheel.

1. Adjusting the potentiometer (this can be done while it is still connected to the machine)

- Run the I/O test mode so that it is displayed on the screen (see 5-5 test mode section).
- Keep the steering wheel level.
- Loosen screws A and move the adjuster plate up and down to adjust. The test mode screen will display "STEERING" When it is settled in the 78 - 82 range tighten the A screws.
- If the range cannot be reached by moving the adjuster plate, loosen screw A a little more and move the pin to another groove, then repeat step 3.

2. Changing the potentiometer

- Disconnect the pot connector.
- Remove stopping screw B and pull out the pot knob.
- Remove the nut on the pot plate and change the pot.
- Once the pot is replaced onto the volume plate (please be careful not to move the pin and pot terminals direction), then reconnect the connector.
- Check to make sure that the "STEERING" on the I/O test mode is in the range of 78 - 82 By moving the pot shaft.
- With this completed, replace the steering wheel. Then go back to "pot adjustment" section to reconfirm the pot value.

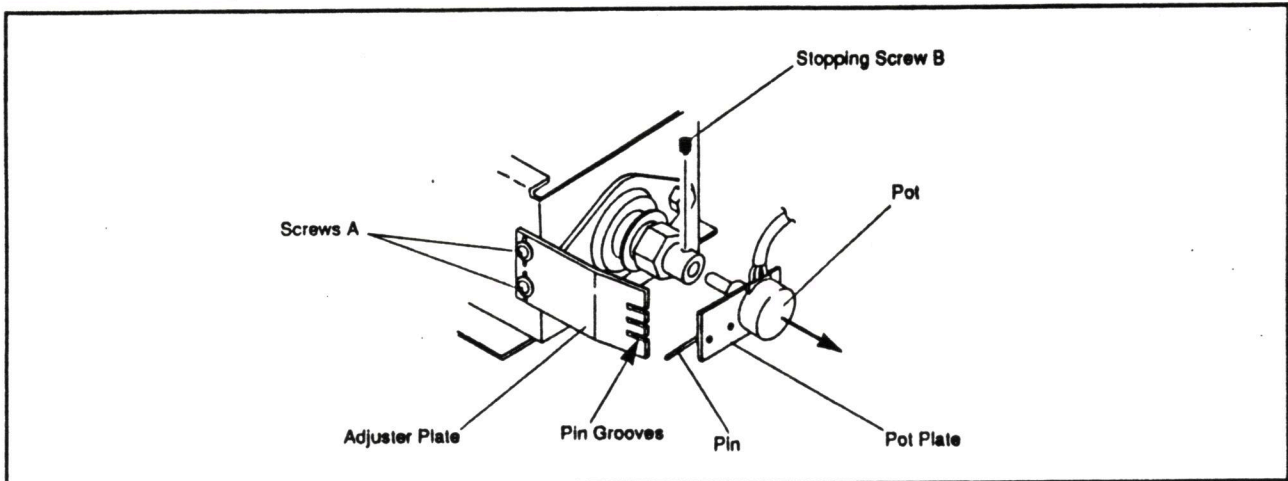

Shift Unit

○ To remove the shift unit, remove the four bolts from the dash cover.

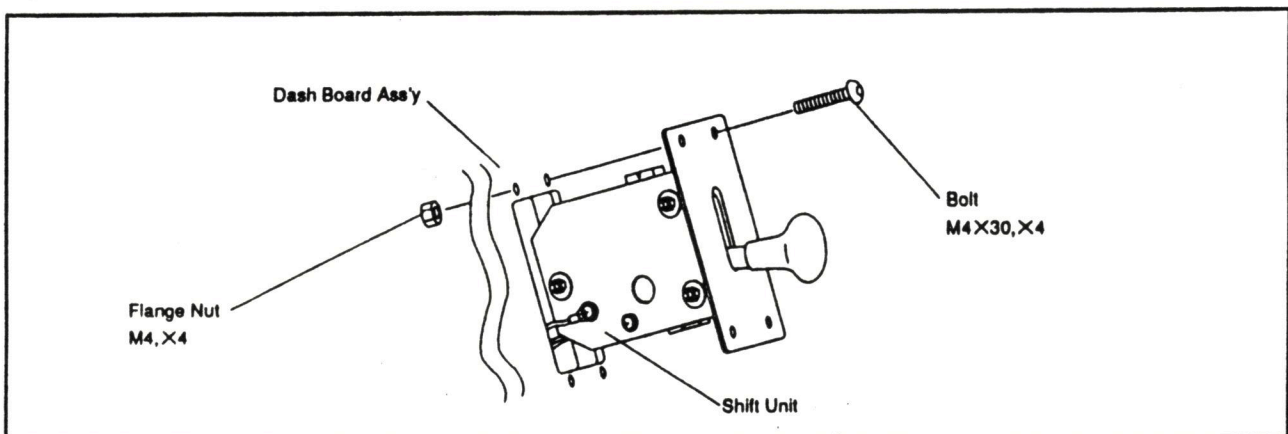

Accelerator / Brake Unit

○ To remove the accelerator, remove the two plate tapping screws from the brake and accelerator pedal respectively, and then remove the four hex bolts from the accelerator / brake unit.

◆ **ATTENTION** : Be sure not to cut the cords when you remove the connectors.

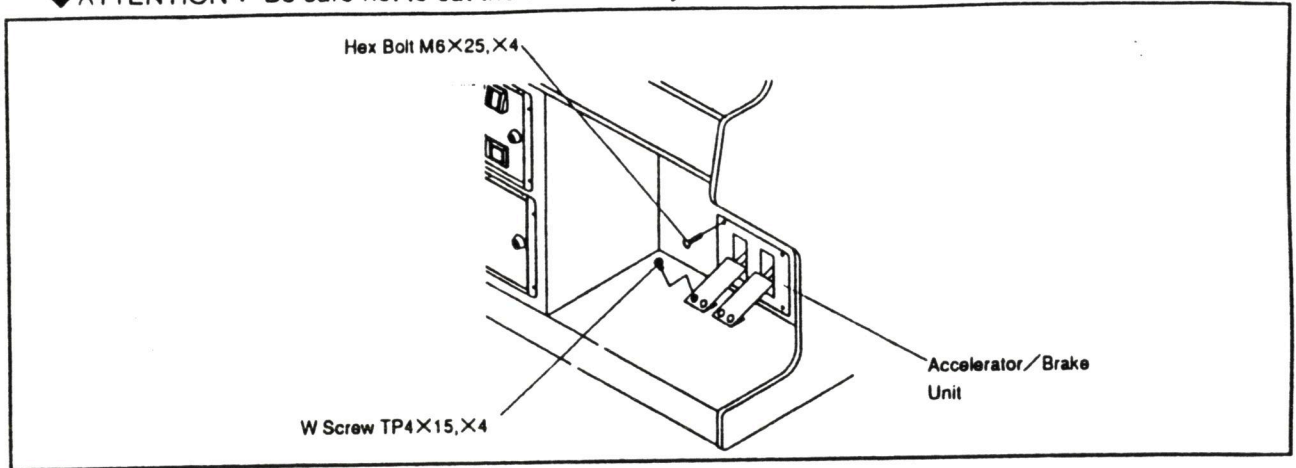

○ Adjusting and changing the potentiometer of the accelerator / brake unit.

1. Adjusting the potentiometer (this can be done while it is still connected to the machine).

• Run the I / O test mode so that it is displayed on the screen (see 5-5 test mode section).

• Remove the set screw A.

• Adjust the potentiometer with a small flat tip screw driver until the value for "ACCELE " on the screen is between 70 and 90. (Do not step on the accelerator pedal.)

2. Changing the potentiometer.

• Pull apart the connector from the potentiometer.

• First remove set screw A and then set screw B. The mechanical assembly can now be removed.

• Remove the nut to release the pot and then change it.

• Re - assemble in reverse order. Be sure to perform pot adjustment before putting the set screw A back on.

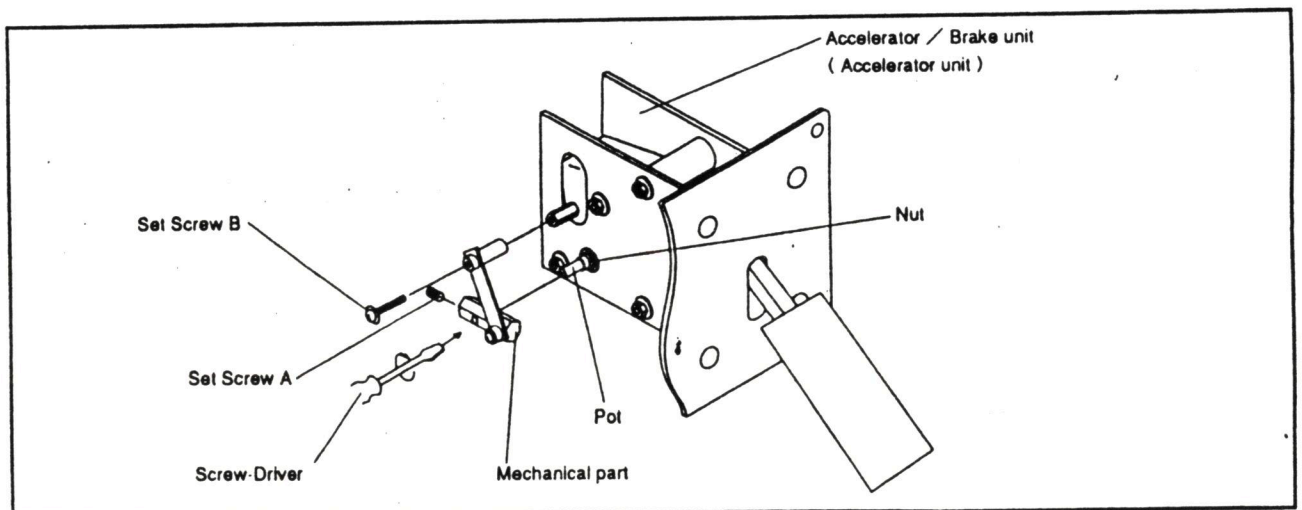

Game P.C.B.'s

- Open the maintenance door, Unscrew the 2 TP 4×25 tapping screws and pull the P.C.B. unit straight up.

ATTENTION : While removing the P.C.B., Be careful not to damage the cords.

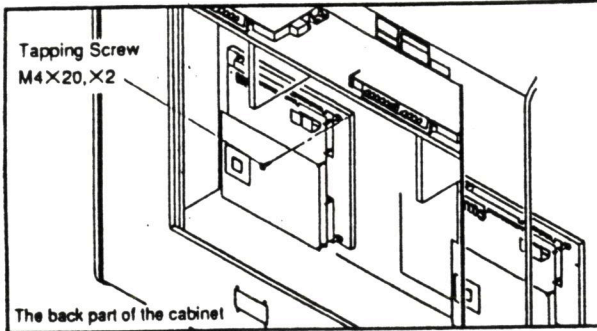

Power Unit

- The Power unit can be found on the lower part of the back of the cabinet. If the fuse blows, replace in with a 8 A fuse.

ATTENTION : Before replacing a blown fuse , be sure to find the cause and eliminate it.

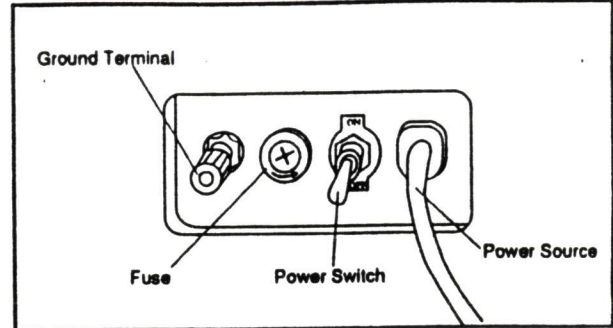

Monitor panel

- To remove the monitor panel, remove the six bolts and monitor bracket.

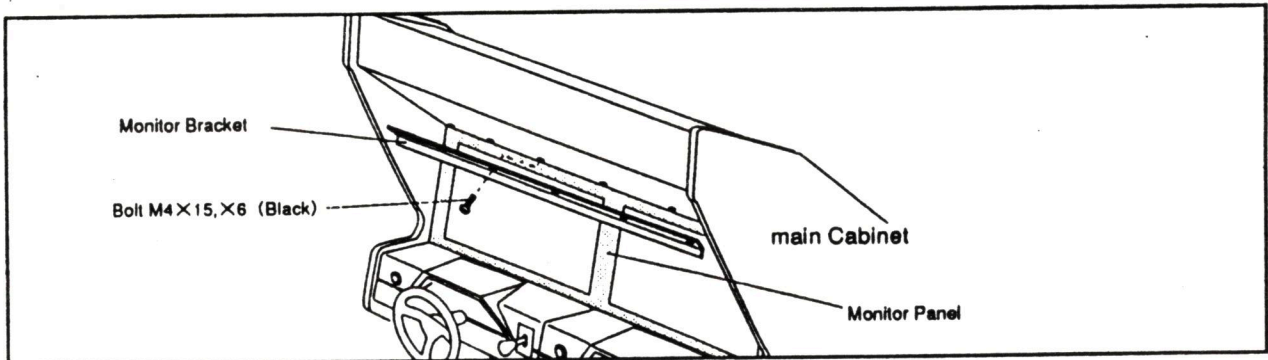

7 SEG P.C.B.

- To remove the top panel, remove the top panel bracket (A) and six bolts of the top bracket (B). Then remove the 7 SEG panel and connector, take out the 7 SEG P.C.B.

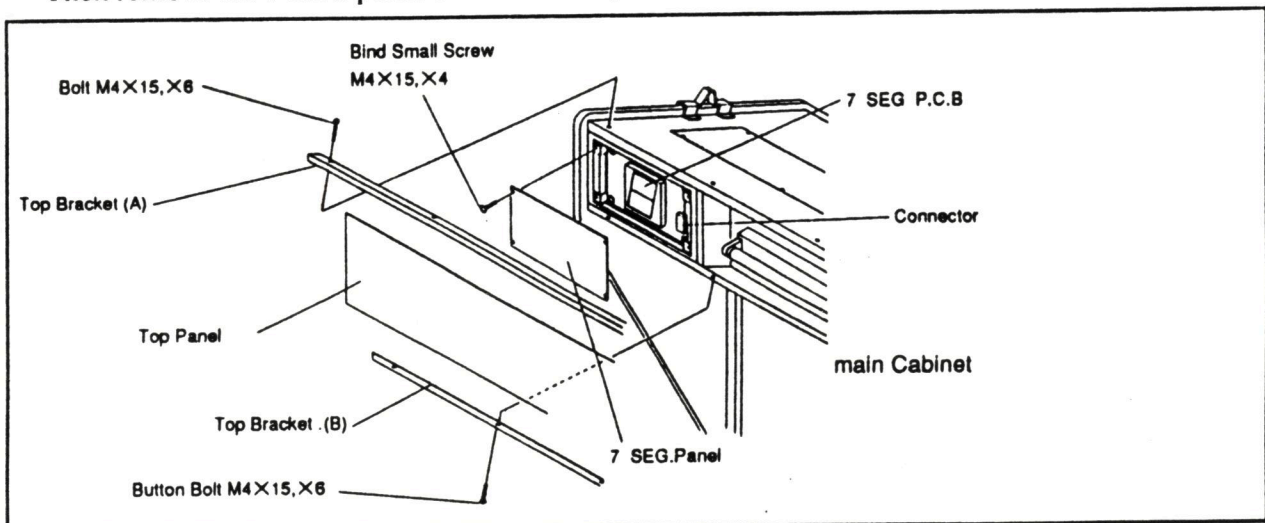

STEERING UNIT ASS'Y

Parts List

NO.	ITEM NUMBER	DESCRIPTION	QTY.	REMARKS
1	MB-40-40807-0	JOINT BAR	2	
2	MB-10-40667-1	VOLUME BRACKET	2	
3	MB-30-40808-2	CRANK SHAFT	2	
4	MB-30-40669-0	STEERING KEY	2	
5	MB-60-40670-0	VOLUME PIN	2	
6	MB-70-40671-2	STEERING STOPPER	2	
7	MB-10-40809-0	CAM-PLATE	2	
8	MB-30-40673-0	BEARING SPACER	2	
9	MB-10-40703-0	FLOATING W	2	
10	MB-60-40823-1	CENTERING SPRING	2	
11	MB-50-30504-0	STEERING CENTER STICKER	2	
12	MB-30-30453-2	CENTERING CAM	2	
13	MB-10-30554-0	MOTOR BRACKET (A)	2	
14	MB-10-30454-1	STEERING BRACKET (B)	2	
15	MB-10-30555-0	MOTOR BRACKET (B)	2	
16	MB-30-30556-1	CRANK	2	
17	MB-10-30456-1	STOPPER BRACKET	2	
18	MB-10-30562-0	PIN GUIDE 2	2	
19	MB-30-30457-2	BOSS	2	
20	MB-30-20268-3	STEERING SHAFT	2	
21	MB-10-10113-3	STEERING BRACKET (A)	2	
22	MB-90-10114-1	STEERING WHEEL	2	
23				
24				
25				
26				
27	PM-20-00015-0	DC GEARED MOTOR	2	
28	MC-40-00004-0	STEEL DIAMOND SHAPED FLANGE UNIT	4	
29	MC-41-00003-0	ROD END BEARING	4	
30	MC-40-00003-0	MINIATURE BEARING	2	
31	MC-42-00003-0	OILES BUSHING (# 80)	4	
32	MC-42-00004-0	OILES BUSHING (# 80)	4	
33	VR-30-00002-0	VOLUME 5K Ω	2	
34				
35				
36				

NO.	ITEM NUMBER	DESCRIPTION	QTY.	REMARKS
37				
38	MS-12-30**8-C	(+)W SCREW (PAN) 3P3×8	4	
39	MS-12-40**8-C	(+)W SCREW (PAN) 3P4×8	8	
40	MS-12-40*10-C	(+)W SCREW (PAN) 3P4×10	4	
41	MS-12-40*30-C	(+)W SCREW (PAN) 3P4×30	4	
42	MS-12-50*10-C	(+)W SCREW (PAN) 3P5×10	8	
43	MS-12-50*15-C	(+)W SCREW (PAN) 3P5×15	12	
44	MS-40-06*20-C	(6)HEXAGONAL BOLT M6×20	8	
45	MS-40-08*20-C	(6)HEXAGONAL BOLT M8×20	8	
46	MS-41-04*15-C	(6)HEXAGONAL SOCKET HEAD CAP SCREW M4×15	8	
47	MS-41-06*20-C	(6)HEXAGONAL BOLT M6×20	8	
48	MS-53-40**5-D	(6)HOLLOW (WITH CUP POINT) M4×5	2	
49	MS-53-50*15-D	(6)HOLLOW (WITH CUP POINT) M5×15	2	
50	MN-00-***60-C	HEXAGONAL NUT-1 N6	10	
51	MN-00-***80-C	HEXAGONAL NUT-1 N8	8	
52	MN-00-**160-C	HEXAGONAL NUT-1 N16	2	
53	MN-11-***50-C	FLANGE NUT WITH SLATE FN5	14	
54	MW-00-***40-C	WASHER PW4	4	
55				
56	MW-00-***80-C	WASHER PW8	8	
57	MW-00-**160-C	WASHER PW16	2	
58	MW-00-**200-C	WASHER PW20	6	
59	MW-10-***50-C	SPRING WASHER SW5	2	
60	MW-10-***60-C	SPRING WASHER SW6	14	
61	MW-10-***80-C	SPRING WASHER SW8	8	
62	MW-10-**160-C	SPRING WASHER SW16	2	
63	MW-17-***60-D	PAN SPRING (HEXAGONAL BOLT)	6	
64	MW-20-E**30-C	"E" STOPPER RING	4	
65	MW-22-C*200-D	"C" STOPPERRING	4	
66				
67				
68				
69				
70				
71				
72				

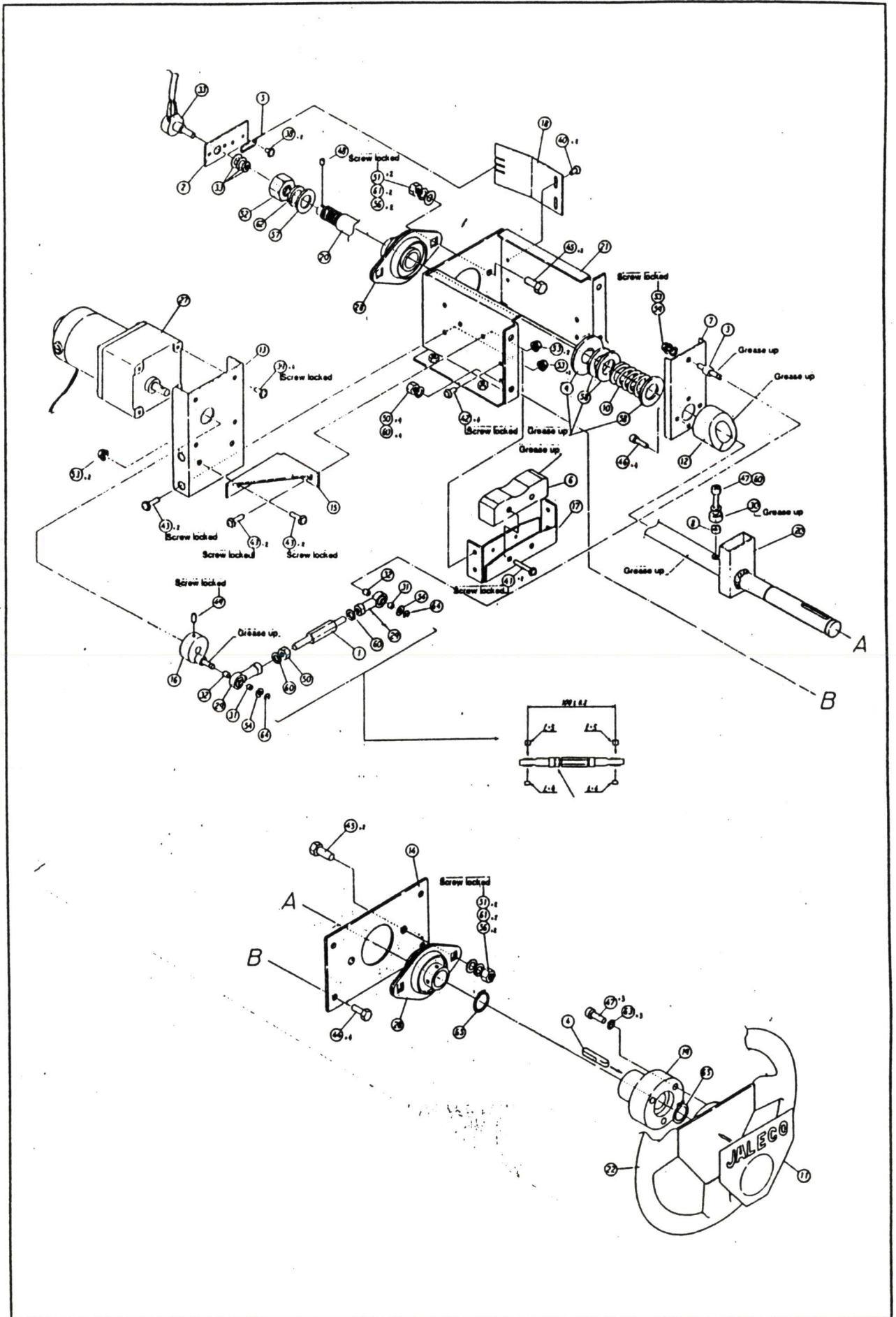

ACCELE/BRAKE UNIT ASS'Y

NO.	ITEM NUMBER	DESCRIPTION	QTY.	REMARKS
1	MB-10-20563-0	ACCELERATOR COVER	2	
2	MB-10-20564-0	BRAKE PEDAL	4	
3	MB-10-31180-0	ACCELERATOR ARM	4	
4	MB-10-20562-0	ACCELERATOR BRACKET (A)	4	
5	MB-10-31181-0	ACCELERATOR BRACKET (B)	4	
6	MB-70-40399-0	PEDAL RUBBER	8	
7	MB-30-41771-0	SWITCH POST $\phi 8 \times L25$	4	
8	MB-30-40402-0	PEDAL SHAFT	16	
9	MB-30-40676-1	BAR GUIDE	4	
10	MB-10-40677-0	VOLUME BAR	2	
11	MB-30-40678-0	VOLUME ARM	2	
12	MB-60-40679-0	ACCELERATOR SPRING	4	
13	MB-10-41763-0	ACCELERATOR LINK	8	
14	MB-10-41884-0	HEXAGONAL SOCKET HEAD CAP SCREW	8	
15	SW-60-00002-0	MICRO SWITCH	2	
16	VR-30-00001-0	VOLUME	2	
17	MC-42-00005-0	FLANGE BUSHING	8	
18	MS-12-30*10-C	(+)W SCREW (PAN) 3P3×10	2	
19	MS-12-30*15-C	(+)W SCREW (PAN) 3P3×15	4	
20	MS-12-30*30-C	(+)W SCREW (PAN) 3P3×30	2	
21	MS-12-30*35-C	(+)W SCREW (PAN) 3P3×35	2	
22	MS-04-50*60-C	(+)SMALL SCREW (BIND)M5×60	16	
23	MS-46-50*15-D	PAN HEAD BOLT M5×15	16	
24	MS-53-40**8-D	(6)HOLLOW (WITH CUP POINT)M4×8	2	
25	MN-11-***50-C	FLANGE NUT WITH SLATE FN5	40	
26	MW-00-***40-C	WASHER PW4	16	
27	MN-70-***40-C	NUT	8	
28				
29				
30				
31				
32				
33				
34				
35				
36				

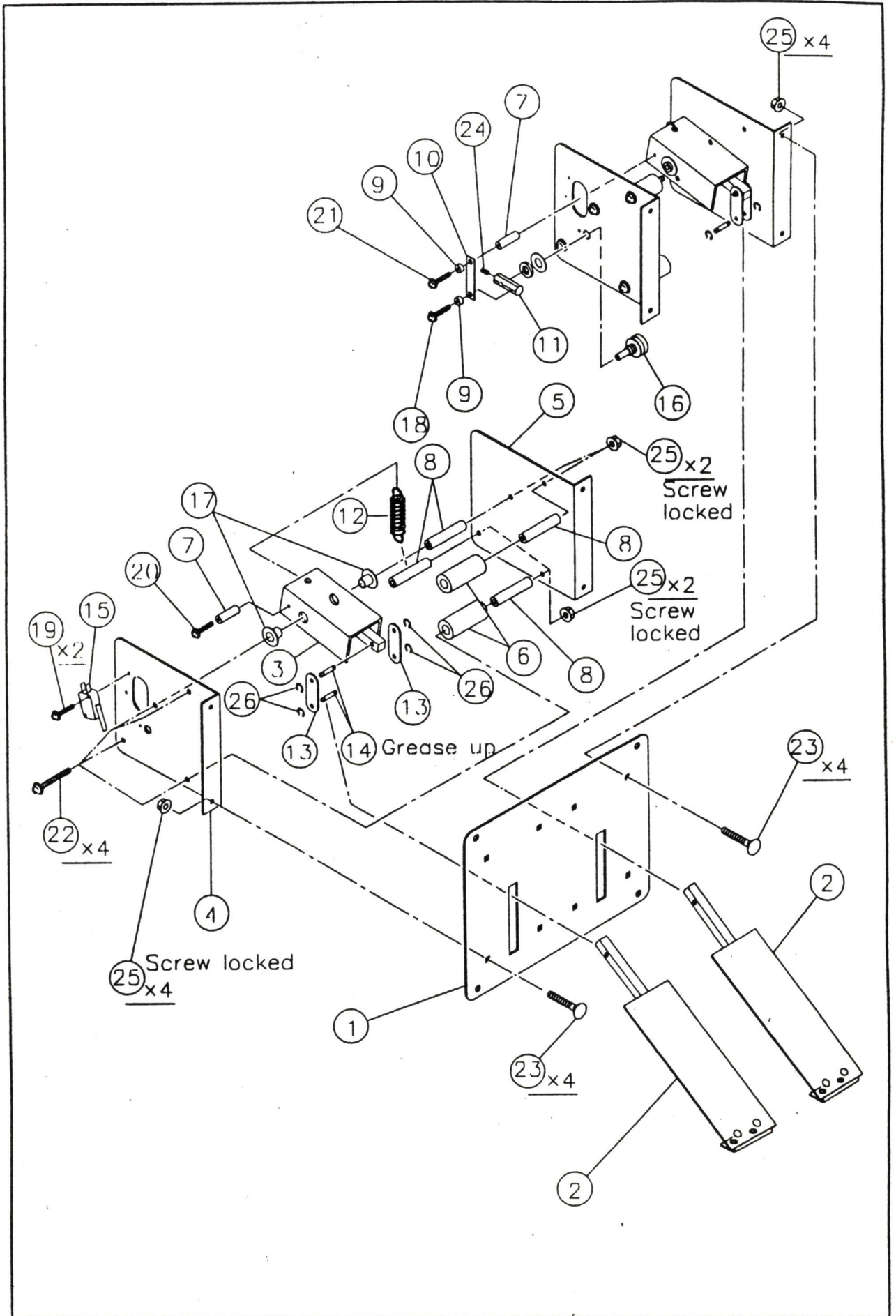

SHIFT UNIT ASS'Y

NO.	ITEM NUMBER	DESCRIPTION	QTY.	REMARKS
1	MB-30-30644-0	SHIFT ARM V2	2	
2	MB-10-30560-0	SHIFT PANEL	2	
3	MB-50-40816-1	SHIFT STICKER	2	
4	MB-10-30404-0	THROTTLE PLATE	4	
5	MB-10-40815-0	CLICK PLATE	4	
6	MB-10-40559-1	SPACER (A)	4	
7	MB-30-40560-1	ARM LIMITER	2	
8	MB-70-40561-1	THROTTLE COVER	2	
9	MB-30-40562-1	THROTTLE SHAFT	6	
10	MB-30-40563-0	SPACER(B)	4	
11	MB-70-40564-0	THROTTLE RUBBER	4	
12	MB-60-40565-0	CLICK SPRING	4	
13	MB-60-40566-3	SWITCH PIN	2	
14	MB-10-40083-1	SWITCH PLATE	2	
15	MC-26-00007-0	SHIFT KNOB No.4	2	
16	MB-30-40907-0	KNOB PIPE	2	
17	SW-60-00003-0	MICRO SWITCH	2	
18	MS-12-30*18-C	(+)W SCREW (PAN) 3P3×18	4	
19	MS-12-30*10-C	(+)W SCREW (PAN) 3P3×10	2	
20	MS-40-05*50-C	HEXAGONAL BOLT M5×50	6	
21	MN-70-***40-C	NUT N4	8	
22	MN-11-***50-C	FLANGE NUT WITH SLATE FN5	6	
23	MW-10-***40-C	SPRING WASHER SWITCH 4	8	
24	MW-10-***50-C	SPRING WASHER SWITCH 5	6	
25	MW-71-IS*11-D	"S" STOPPER RING	2	
26				
27				
28				
29				
30				
31				
32				
33				
34				
35				
36				

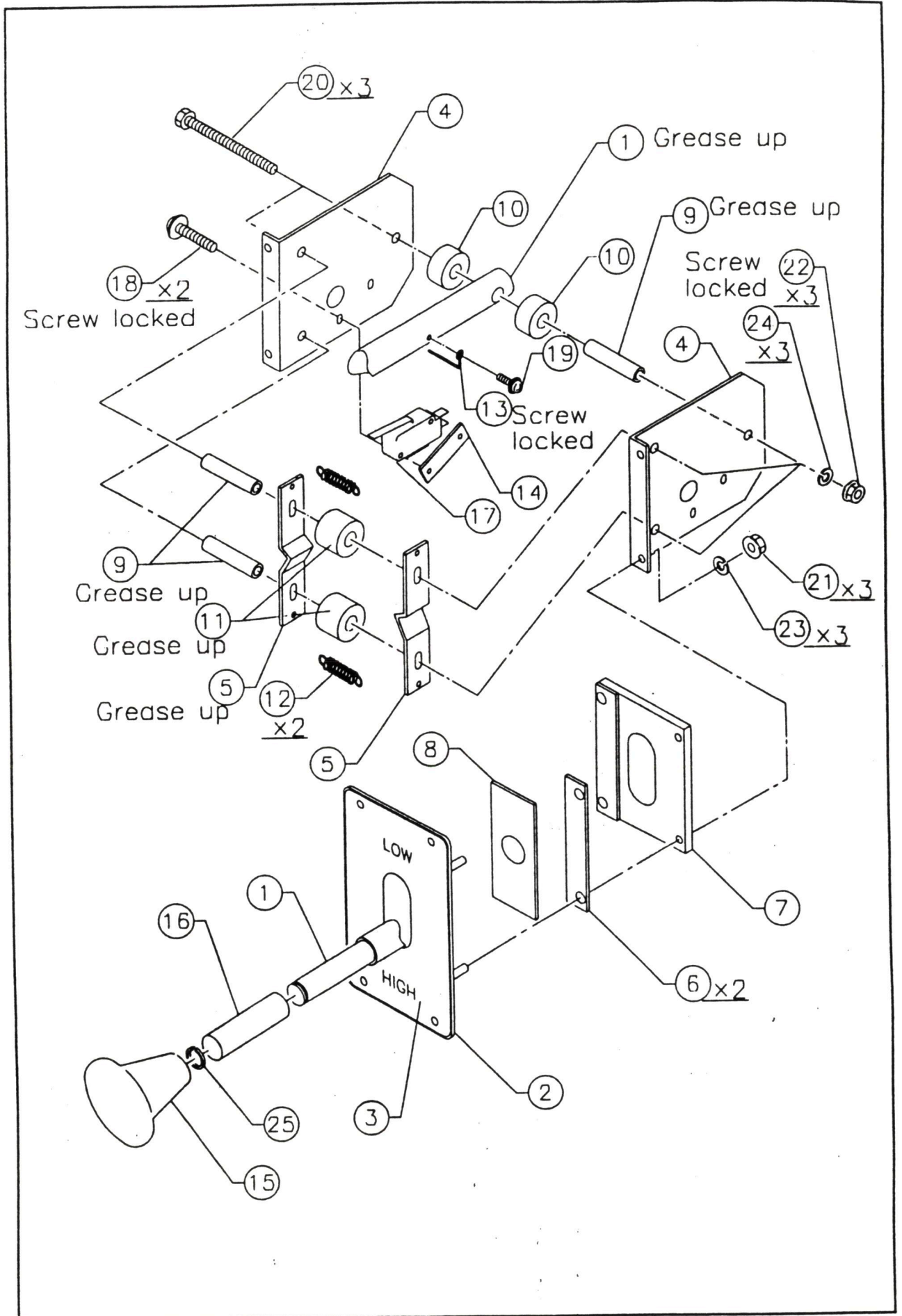

CRT MONITOR ASS'Y

NO.	ITEM NUMBER	DESCRIPTION	QTY.	REMARKS
1	TV-00-00009-0	29" MONITOR	2	
2	MB-10-20527-1	CRT BRACKET (A)	4	
3	MB-10-31121-0	CRT BRACKET (B)	4	
4	MB-10-41654-0	MASKING WOOD BRACKET	4	
5	MB-30-30981-0	HANDLE	4	
6	MB-50-41797-0	HIGH VOLTAGE WARNING STICKER	2	
7	MS-12-40**8-C	(+)W SCREW (PAN) 3P4×8	16	
8	MS-01-40**8-C	(+) PAN SMALL SCREW M4×8	8	
9	MS-14-06*15-C	(+) SCREW (UPSET) 2P6×15	8	
10	MW-65-20*65-C	WASHER PW φ 20× φ 6.5×t1.6	8	
11	MN-11-***80-C	FLANGE NUT WITH SLATE FN8	8	

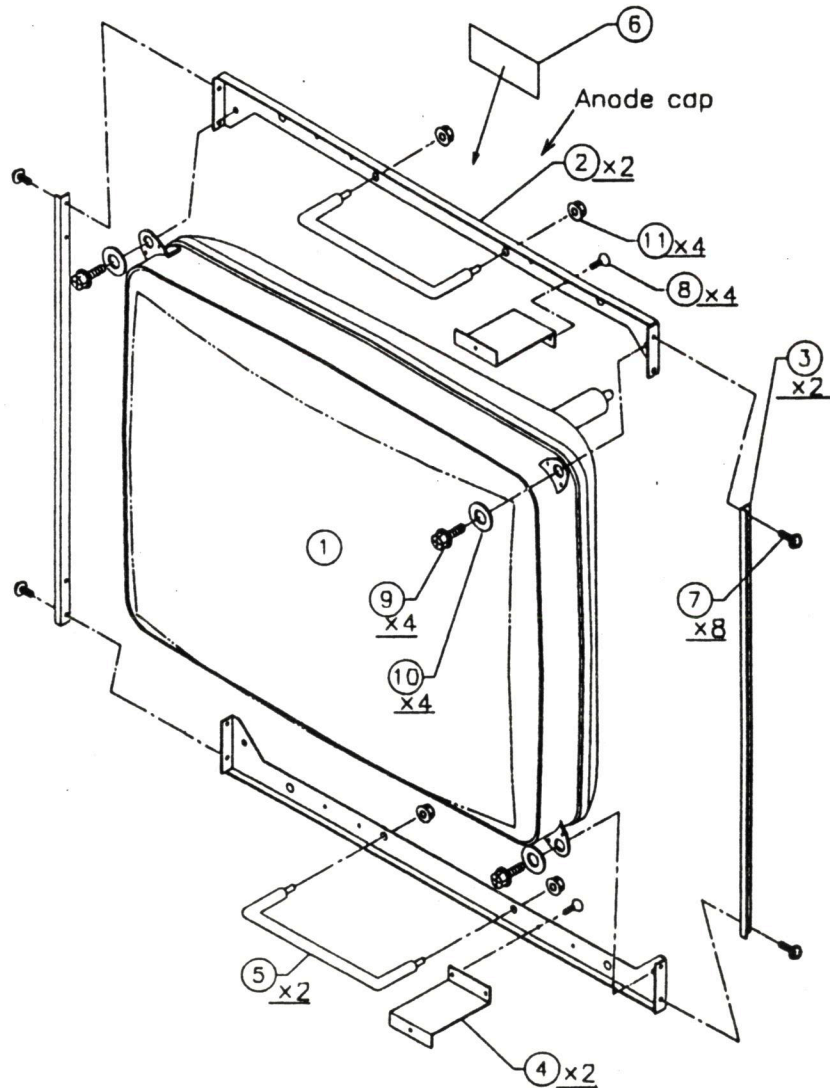

*This view is from the one player side.

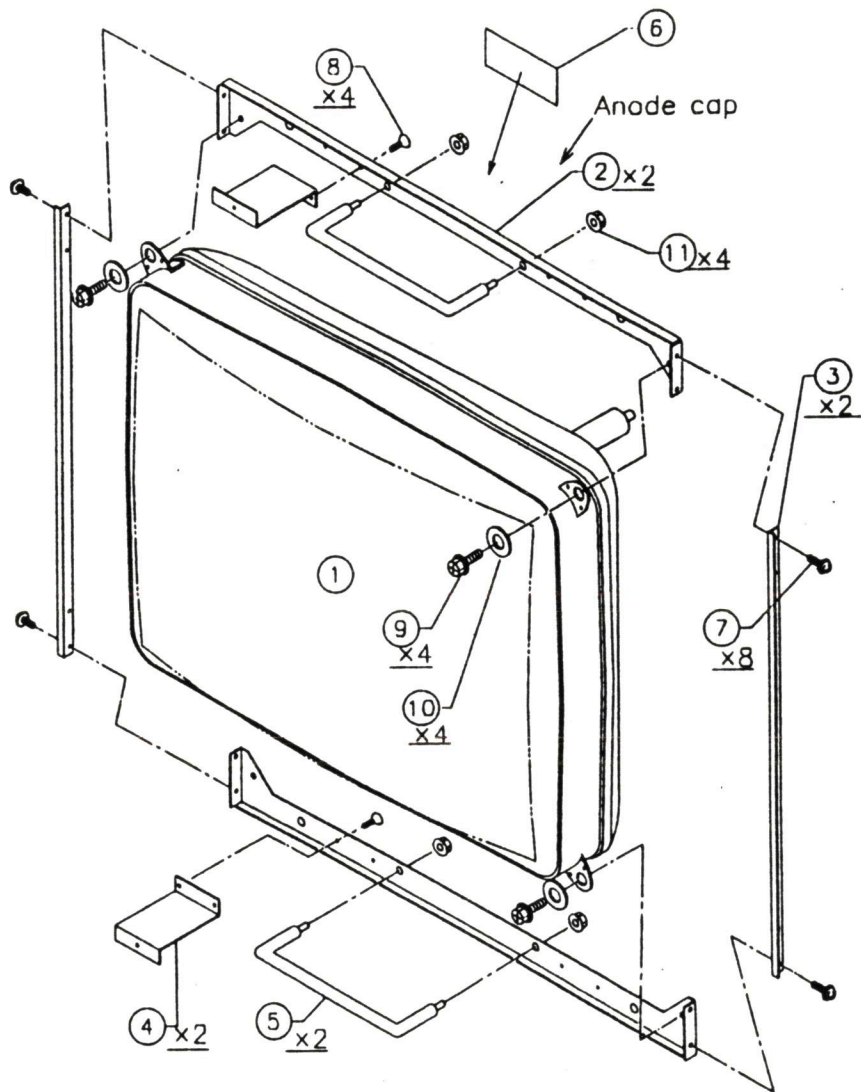

※This view is from the one player side.

POWER SUPPLY-COM ASS'Y

部番	部品番号	名 称	個数	備 考
1	MB-10-30697-2	POWER SUPPLY BRACKET	1	
2	MB-20-31189-0	POWER SUPPLY WOOD	1	
3	MB-10-40170-1	POWER SUPPLY PLATE	1	
4	MB-10-40821-1	COM BRACKET (1)	1	
5	MB-10-40890-0	POWER SUPPLY PLATE P30	1	
6	MB-50-41479-0	POWER SWITCH STICKER	1	
7	MB-50-41482-0	EARTH STICKER	1	
8	MB-50-41067-0	FUSE 8A	1	
9	FF-90-00001-0	FUSE HOLDER	1	
10	TB-00-01P01-0	EARTH TERMINAL	1	
11	CN-25-05P01-0	DIN SOCKET	2	
12	SW-40-00001-0	SLIDE SWITCH	2	
13	SW-20-00002-0	POWER SWITCH	1	
14	SW-99-00001-0	ON/OFF PLATE	1	
15	TB-00-05P01-0	LUG TERMINAL	1	
16	TB-00-04P01-0	FASTEN TERMINAL	1	
17	FL-00-00010-0	NOISE FILTER	1	
18	PS-10-00018-0	POWER SUPPLY HKT100-522	1	
19	PS-10-00023-0	POWER SUPPLY RWS30A-12	1	
20	CN-71-00003-0	AC CORD	1	
21	CN-30-00045-0	STRAIN RELIEF BUSHING	1	
22	XX-40-00003-0	SURGE ABSORBER	2	
23	EB-10-30064-0	TRANSFORMER	1	
24	FF-00-00008-0	FUSE (8A)	1	
25	MS-04-26*10-F	(+) SMALL SCREW (BIND) M2.6×10	4	
26	MS-04-30*10-D	(+) SMALL SCREW (BIND) M3×10	5	
27	MS-01-40**8-C	(+)PAN SMALL SCREW M4×8	5	
28	MS-20-40*20-C	(+)PAN TAPPING SCREW TP4×20	2	
29	MS-25-40*12-C	(+)TORUS TAPPING SCREW TP4×12	10	
30	MN-11-***30-C	FLANGE NUT WITH SLATE FN3	1	
31				
32				
33				
34				
35				
36				

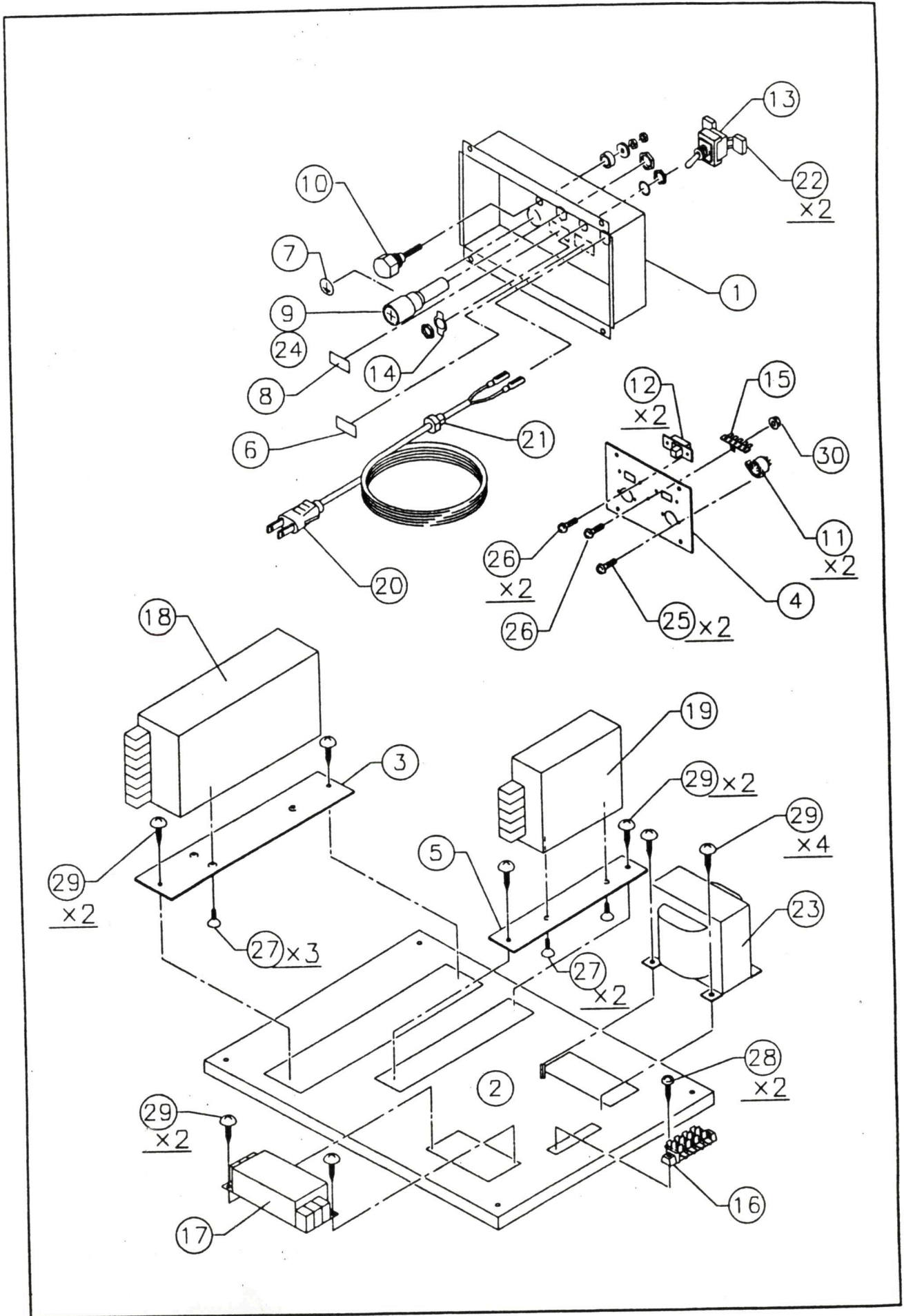

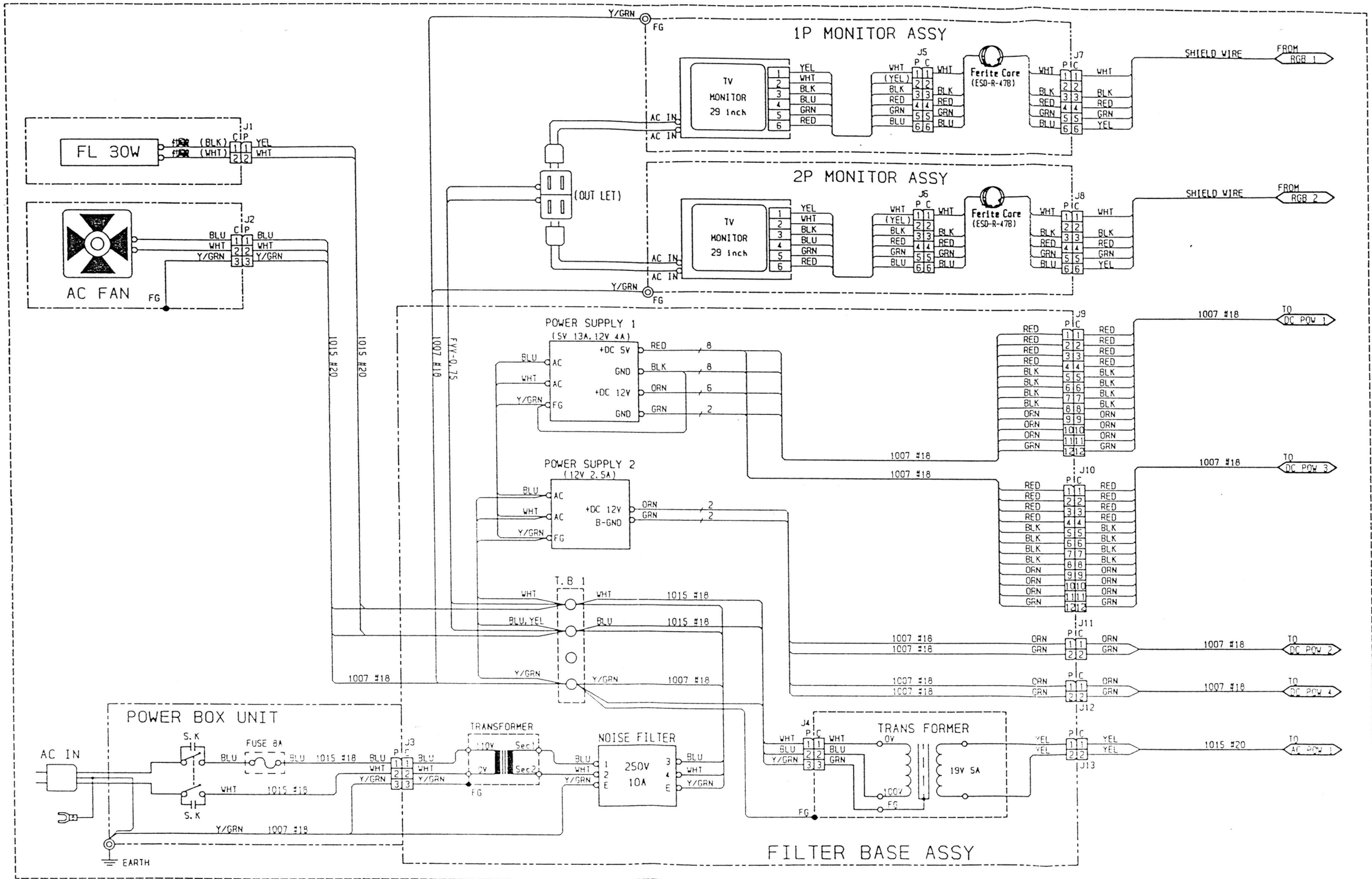

9. General Wiring Diagrams

LEFT PLAYER SIDE

CR7E-44DA-3.96E CN 2 (HIROSE)

1	N.C.
2	GND
3	+12V
4	IP ST
5	N.C.
6	N.C.
7	IP / SCK
8	IP SO
9	GND
10	GND
11	COM. DATA (-)
12	COM. DATA (-)
13	COM. CLK (-)
14	COM. CLK (-)
15	GND
16	N.C.
17	STEERING VR
18	N.C.
19	N.C.
20	N.C.
21	N.C.
22	N.C.
23	N.C.
24	N.C.
25	N.C.
26	N.C.
27	N.C.
28	N.C.
29	N.C.
30	N.C.
31	N.C.
32	N.C.
33	N.C.
34	N.C.
35	N.C.
36	N.C.
37	N.C.
38	N.C.
39	N.C.
40	N.C.
41	N.C.
42	N.C.
43	N.C.
44	N.C.
45	N.C.
46	N.C.
47	N.C.
48	N.C.
49	N.C.
50	N.C.

F1-03150 P.C.B

CR7E-560A-3.96E CN 14 (HIROSE)

1	GND
2	GND
3	GND
4	+DC 5V
5	+DC 5V
6	+DC 5V
7	N.C.
8	N.C.
9	+DC 12V
10	+DC 12V
11	KEY
12	KEY
13	COIN COUNTER
14	N.C.
15	N.C.
16	N.C.
17	N.C.
18	N.C.
19	N.C.
20	N.C.
21	N.C.
22	N.C.
23	N.C.
24	N.C.
25	N.C.
26	N.C.
27	N.C.
28	N.C.
29	N.C.
30	N.C.
31	N.C.
32	N.C.
33	N.C.
34	N.C.
35	N.C.
36	N.C.
37	N.C.
38	N.C.
39	N.C.
40	N.C.
41	N.C.
42	N.C.
43	N.C.
44	N.C.
45	N.C.
46	N.C.
47	N.C.
48	N.C.
49	N.C.
50	N.C.

M8-03140 P.C.B

