

DRAW NO. *main CPU*
 86614 A 1
 DATE
 SCALE NTS / 1:1
 TITLE **TIGER ROAD**
 @DOCTEURPCB
 NOV. 19. 887
CAPCOM

FROM
1

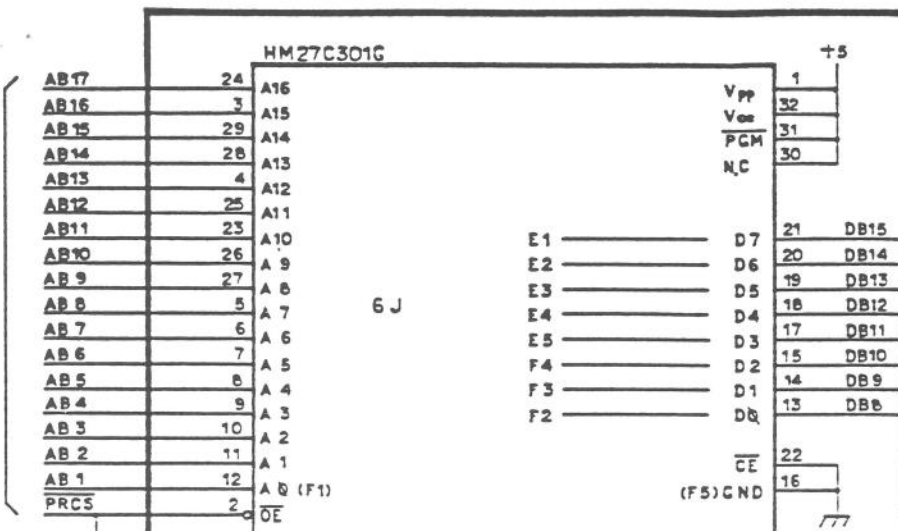

AB18 E7
F7

main CPU Rom/k.m

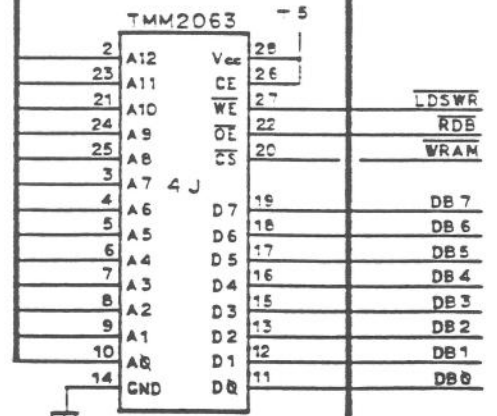
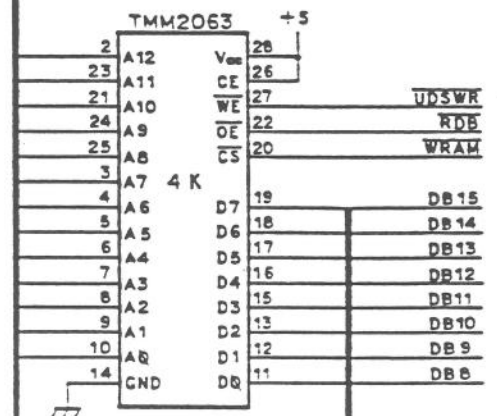

DRAW NO. 86614 A 2		TITLE
DATE	DRAWN CHECKED DESIGNED APPROVED	@DOCTEURPCB
SCALE NTS	1:1	CAPCOM
3RD ANGLE PROJECTION		DIM IN SHEET

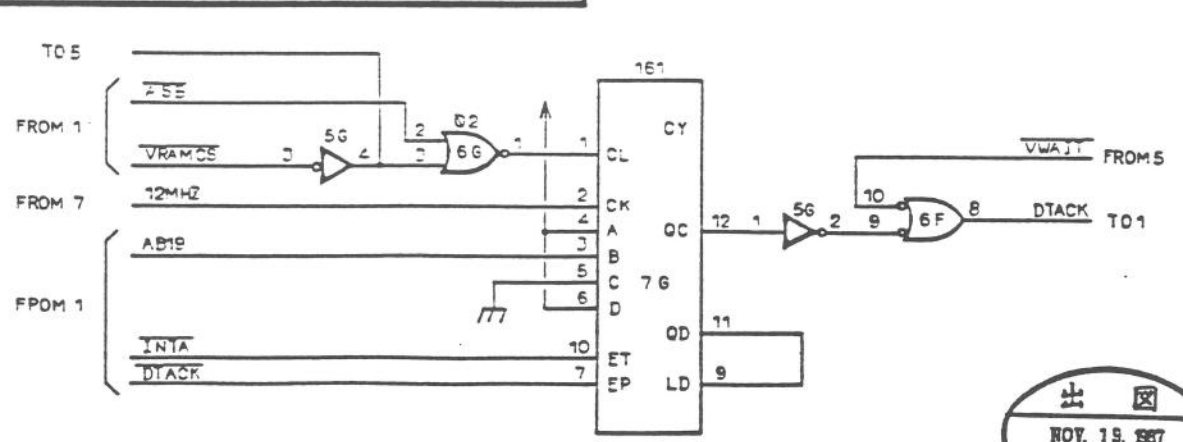
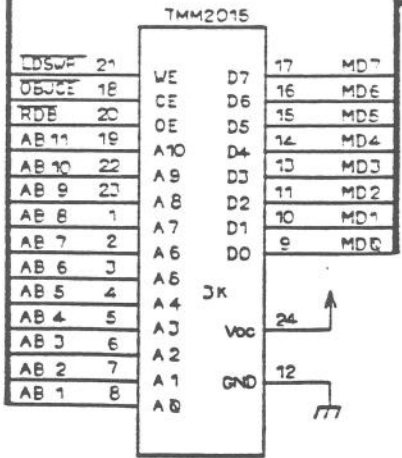
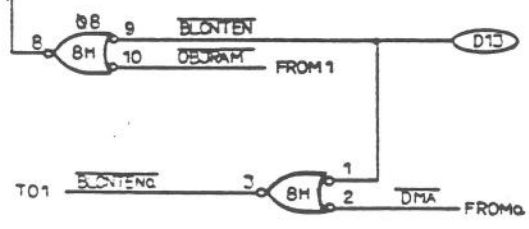
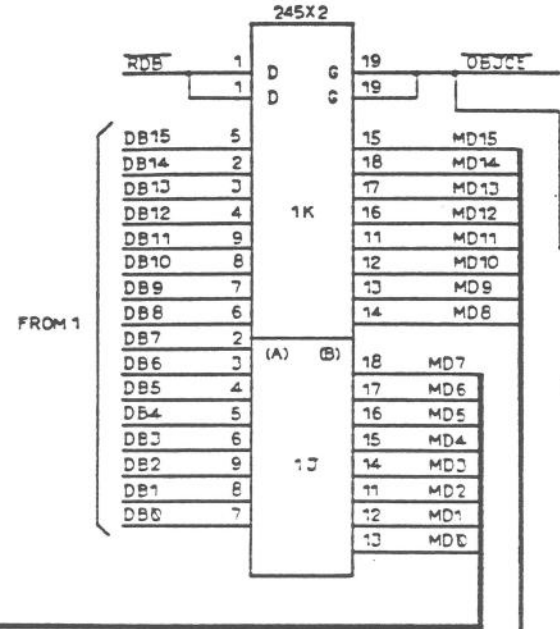
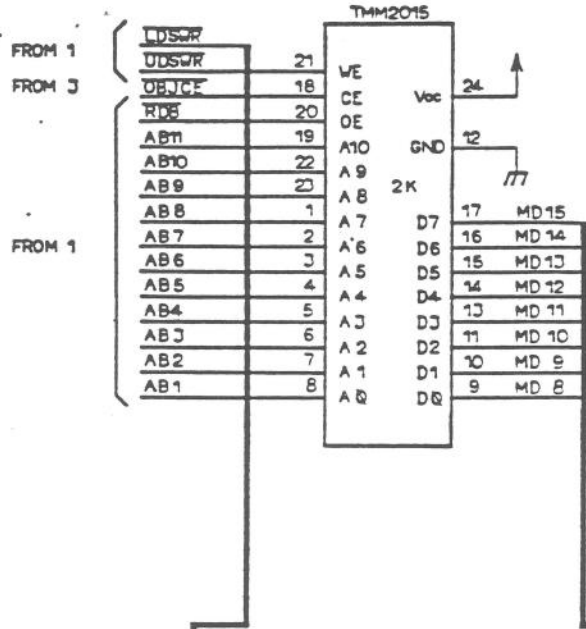

Sprito type select RAM

DRAW NO.	86614	A	3	TITLE	@DOCTEURPCB
DATE		DRAWN	CHECKED	DESIGNED	APPROVED
SCALE	NTS			CAPCOM	
3RD		ANGLE		PROJECTION	
DIM IN		SHEET			

FROM 1

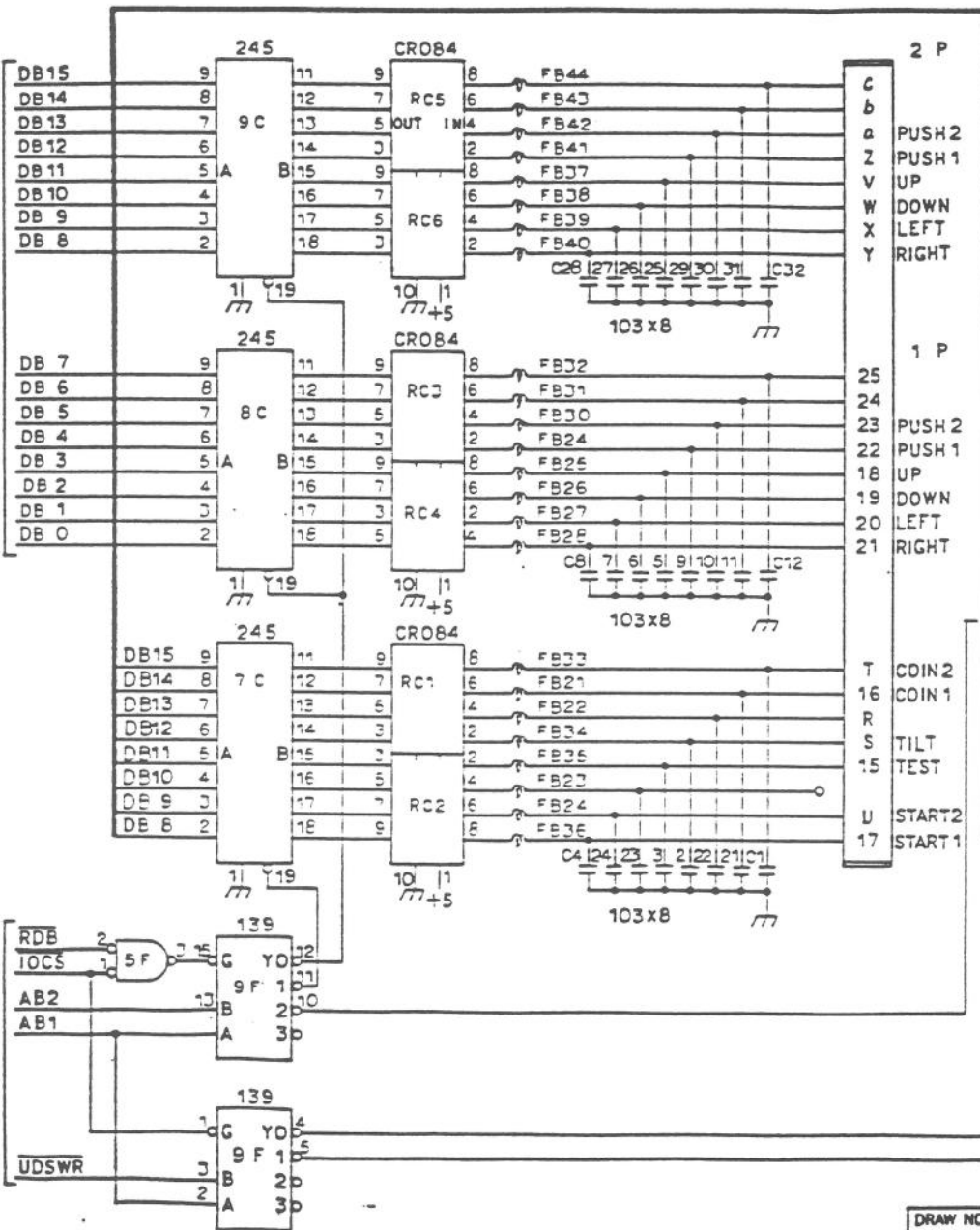

FROM 1

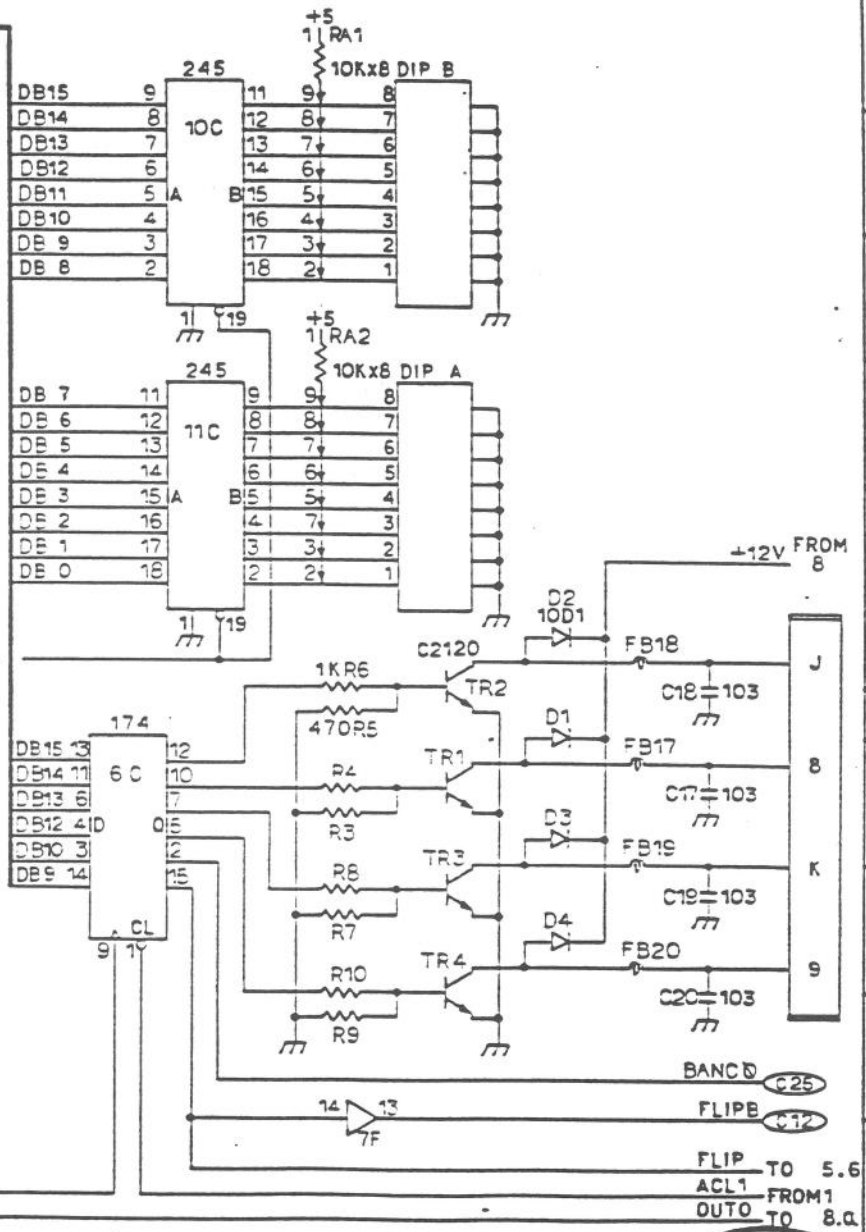
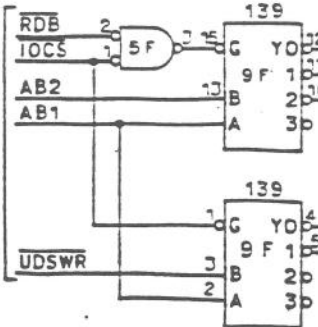

1/0 Parts

DRAW NO.	86614	A	4	TITLE
DATE		DRAWN CHECKED DESIGNED APPROVED		@DOCTEURPCB
SCALE	NTS	CAPCOM		

NOV. 19. 1987

FLIP TO 5.6
ACL1 FROM 1
OUTO TO 8.0

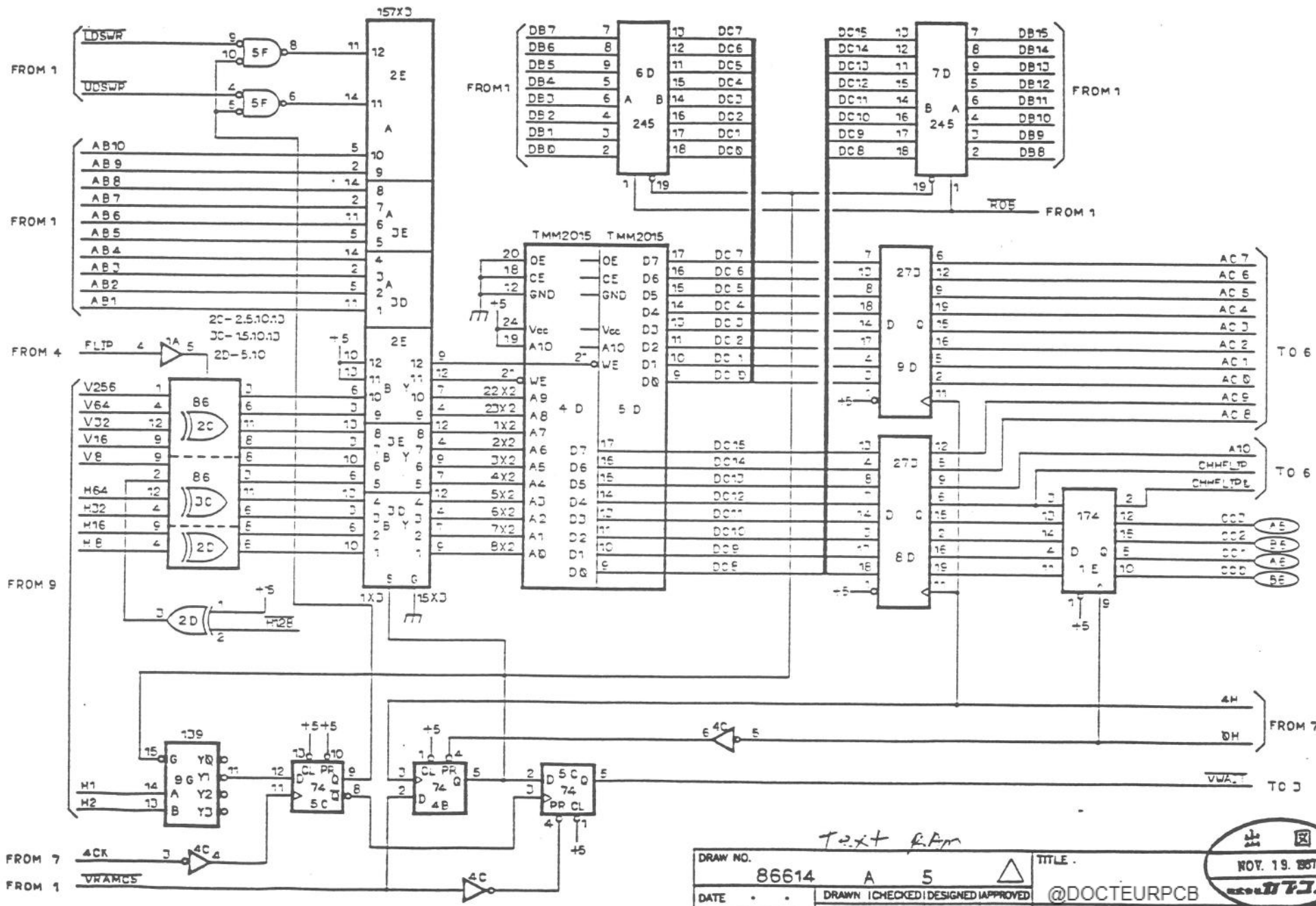

Text & Apr

DRAW NO.		TITLE	
86614 A 5		NOV. 19. 1987	
DATE	DRAWN	CHECKED	DESIGNED
SCALE	NTS		

@DOCTEURPCB
CAPCOM

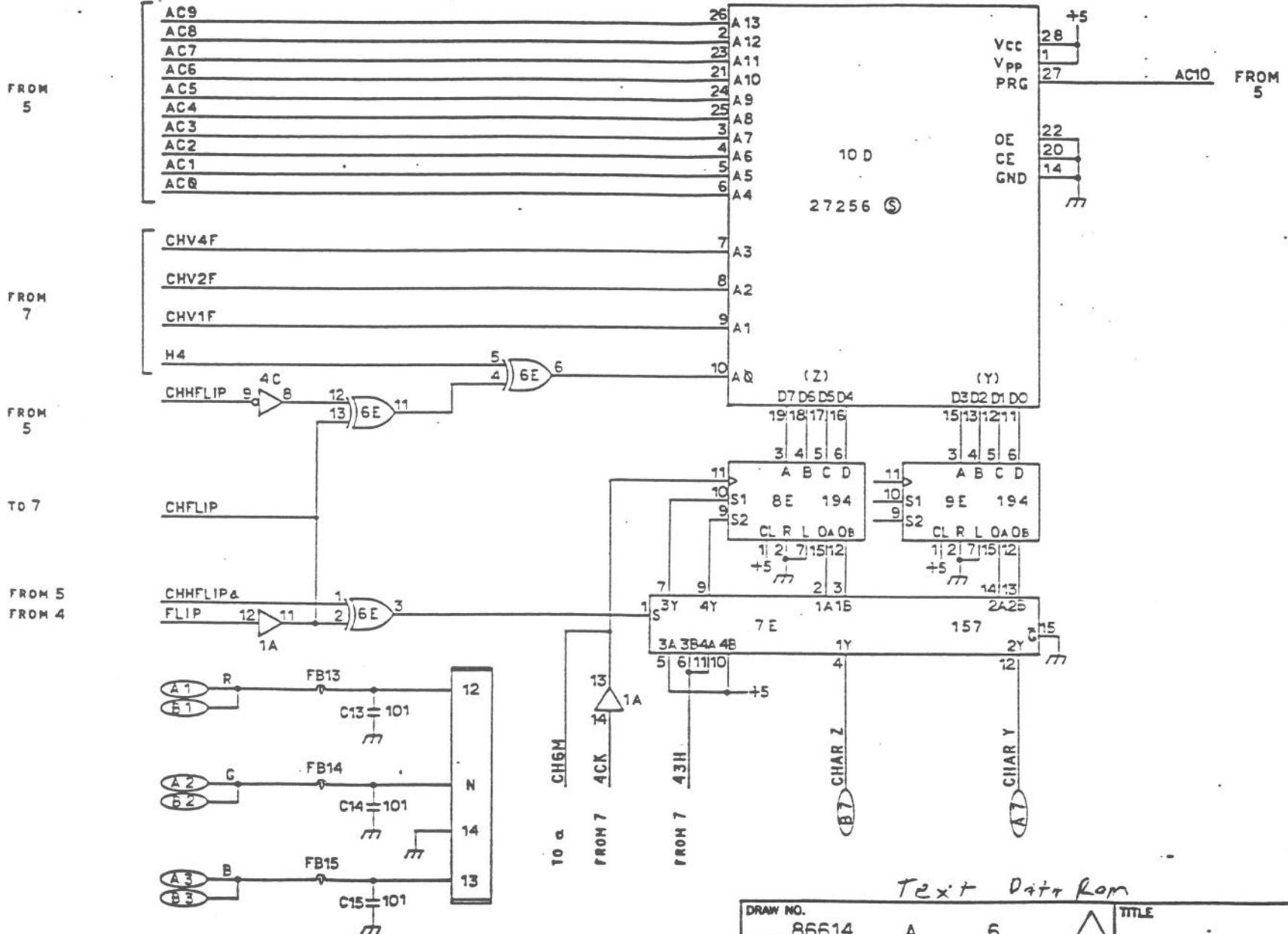

出
NOV. 19. 1987
8733

Text Data Rom

DRAW NO. 86614		A 6		TITLE	
DATE	DRAWN CHECKED DESIGNED APPROVED			©BAR 4BJR58FT X 2	
SCALE NTS				CAPCOM	
3RD		ANGLE		PROJECTION	
DIM		IN		SHEET	

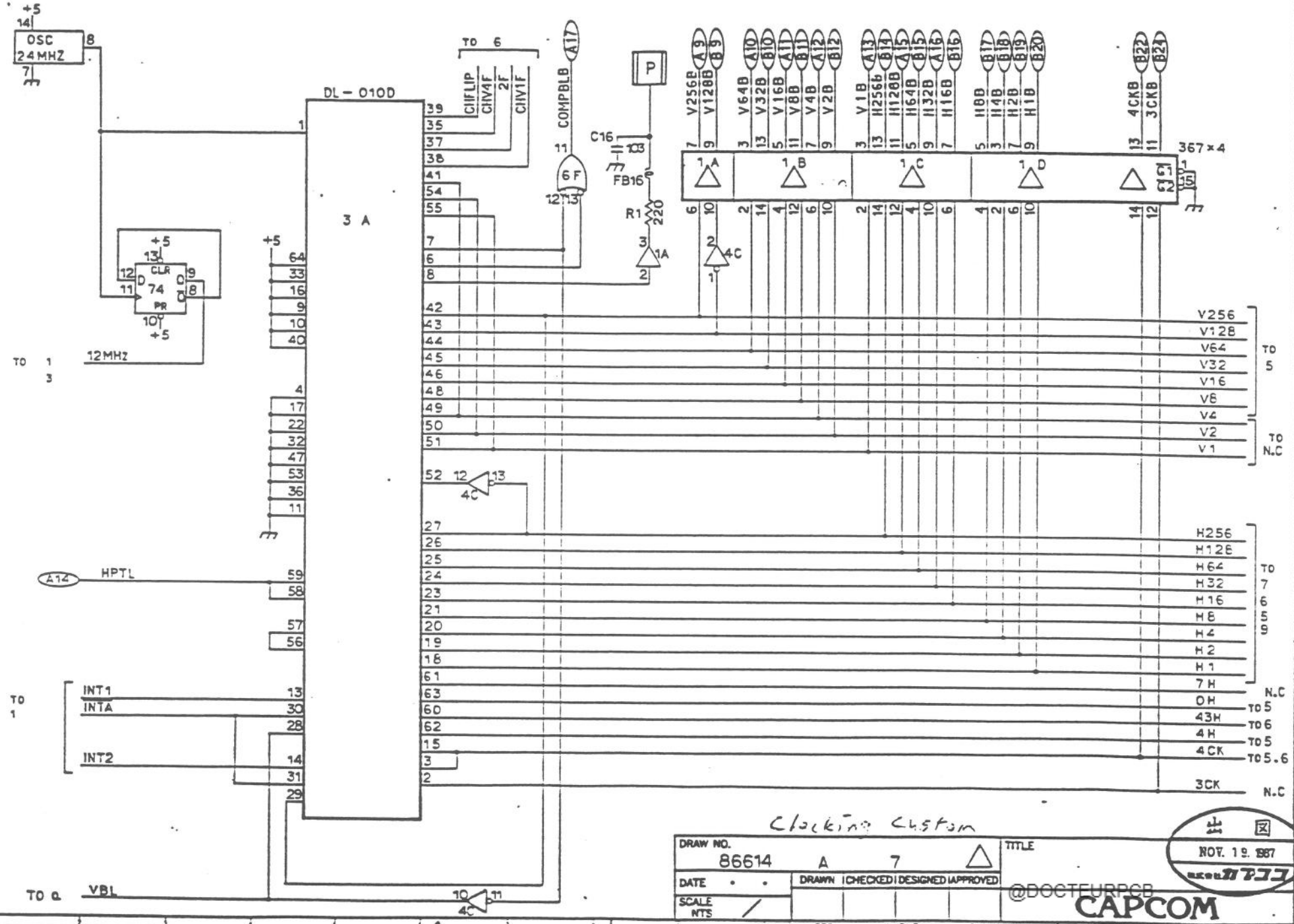

clocking custom

DRAW NO. 86614		A 7		TITLE	
DATE		DRAWN [] CHECKED [] DESIGNED [] APPROVED []		NOV. 19. 1987	
SCALE NTS				@DOCTEURPCB	
				CAPCOM	
3RD		ANGLE		PROJECTION	
DIM		IN		SHEET	



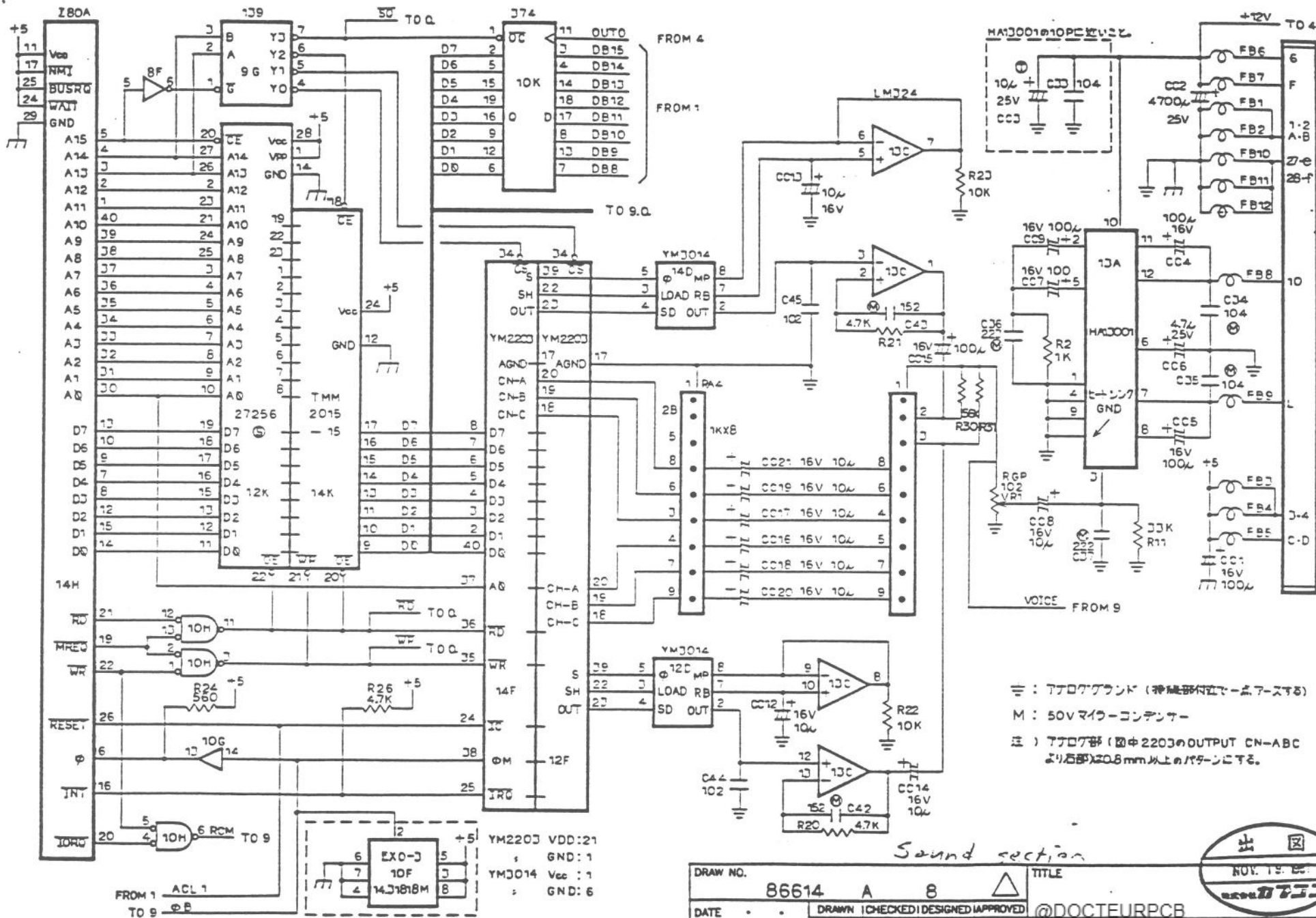

≡ : アナロググランド (接続部分に必ずアースする)
 M : 50V マイラコンデンター
 注) アナログ部 (図中2203のOUTPUT CN-ABC
 より右部)20.8mm以上のパターンにする。

Sound section

DRAW NO.		86614 A B		TITLE	
DATE		DRAWN CHECKED DESIGNED APPROVED		@DOCTEURPCB	
SCALE NTS		有 誤		CAPCOM	
		3RD ANGLE PROJECTION		DIM IN SHEET	



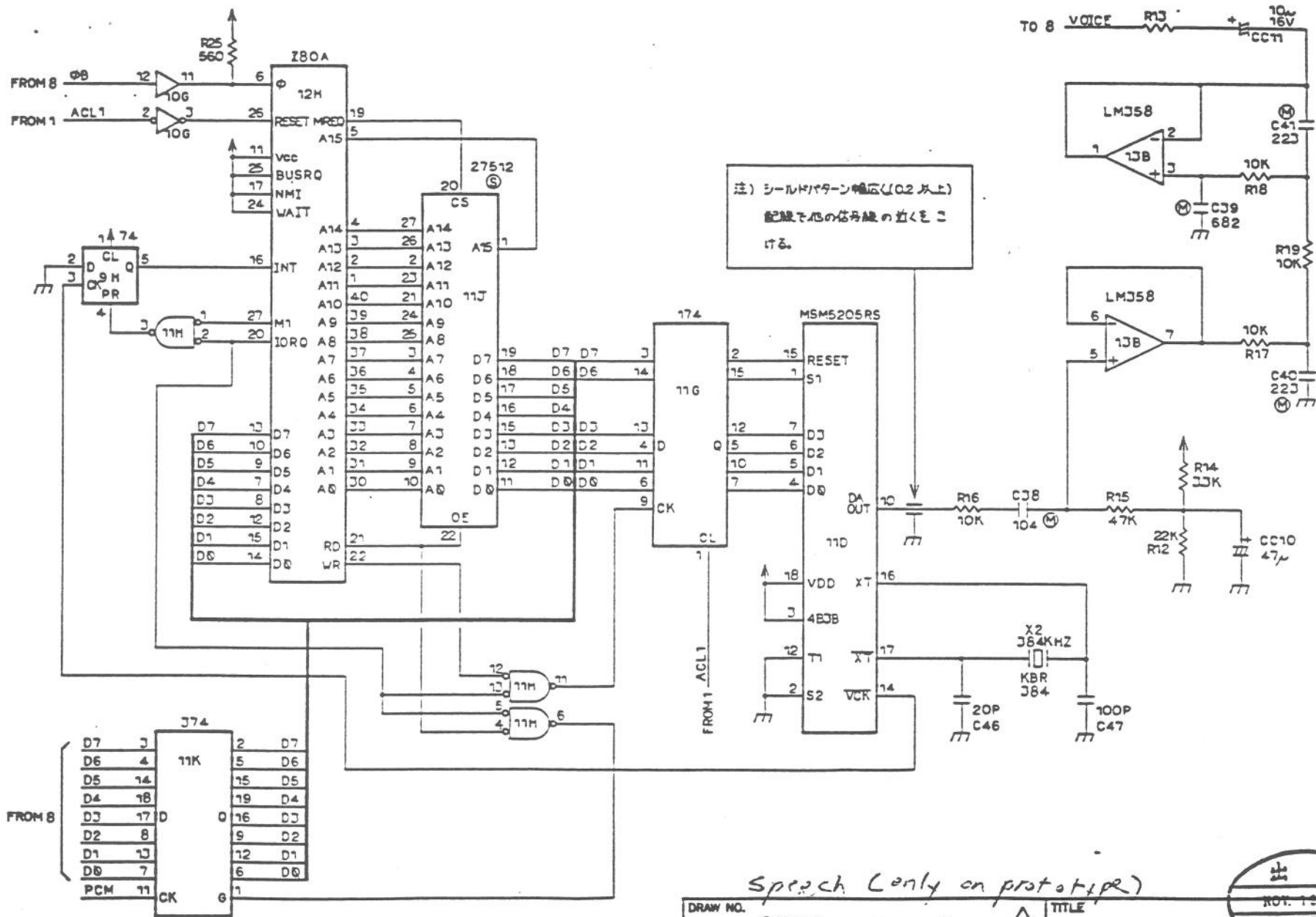

注) シールドパターン輸出(0.2mm以上)
配線で底の信号線の近くをこける。

Speech (only on prototype)

DRAW NO.	86614	A	9
DATE			
SCALE	NTS		

TITLE: @DOCTEURPCB

CAPCOM

PROJECTION: 3RD ANGLE

DIM IN SHEET



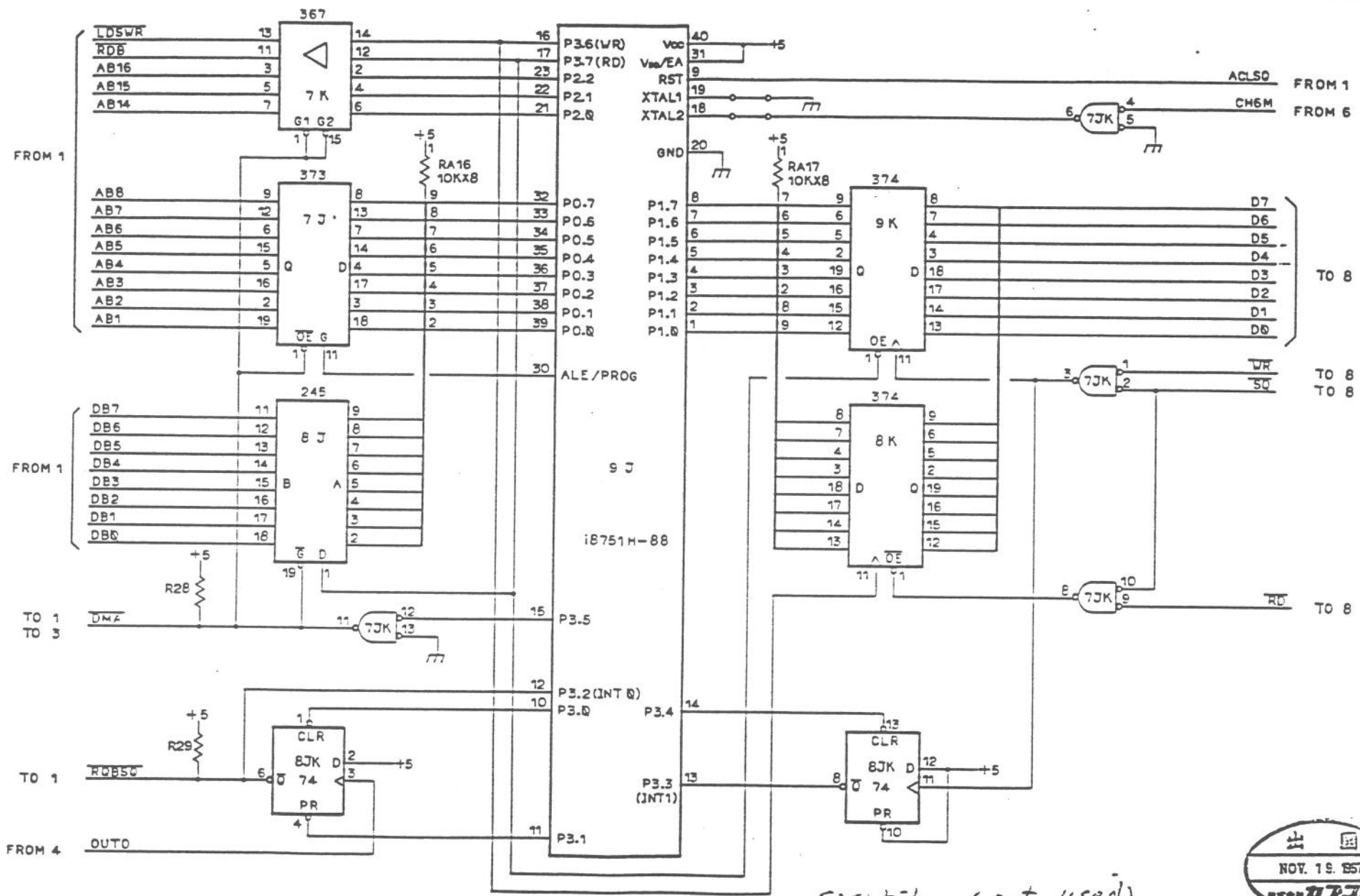

security (not used)



DRAW NO. 86614 A Q		TITLE	
DATE	DRAWN	CHECKED	DESIGNED
SCALE	有藤		
NTS			
3RD ANGLE PROJECTION		DIM IN SHEET	

@DOCTEURPCB

CAPCOM

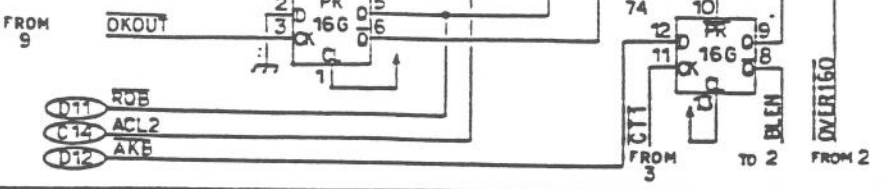
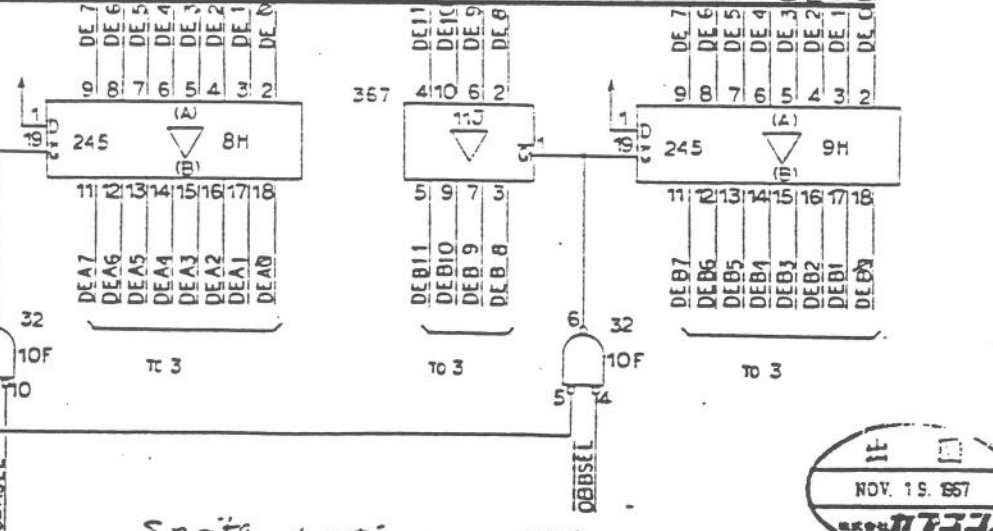
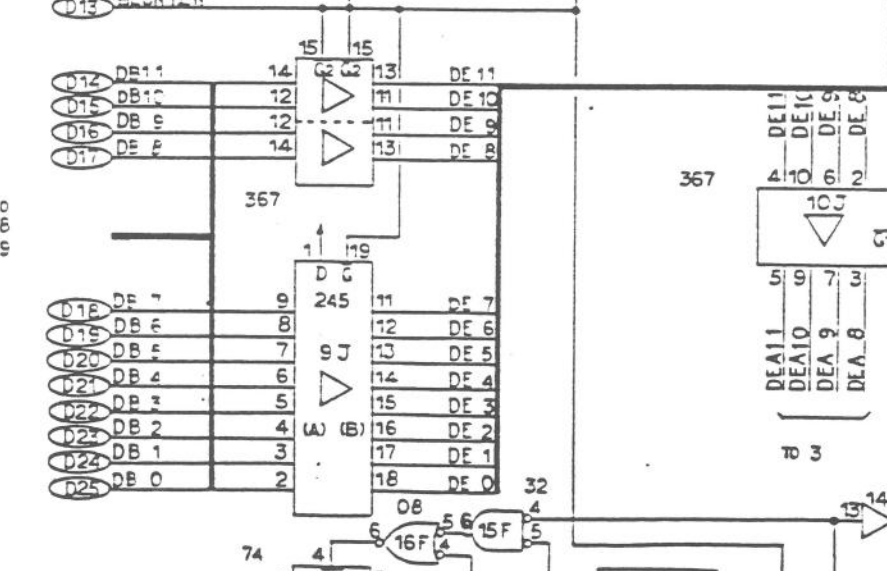
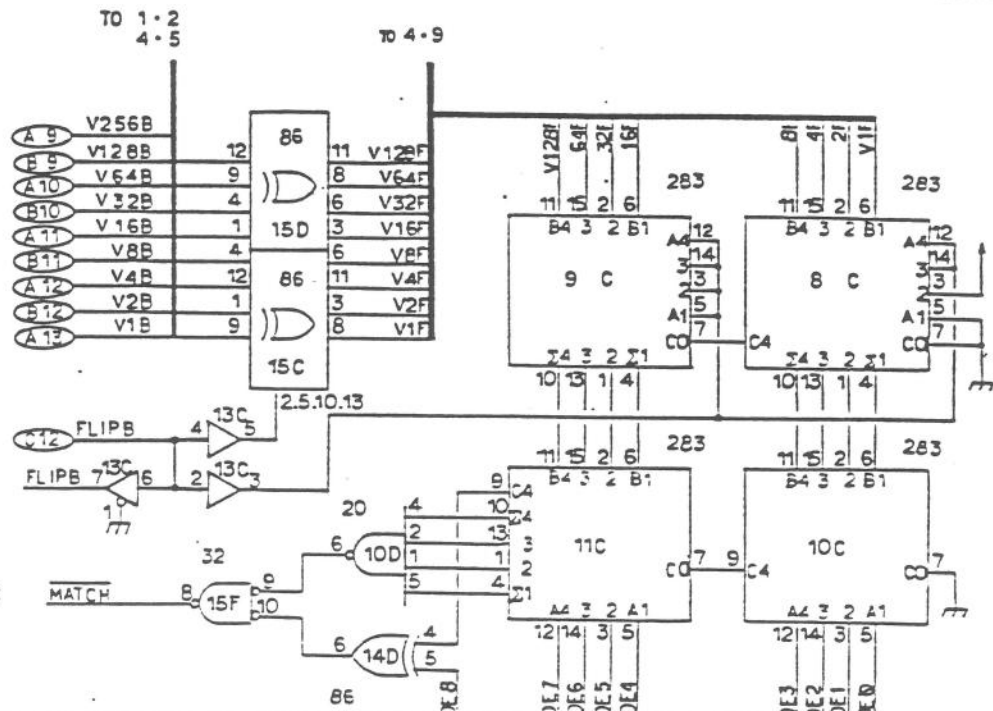
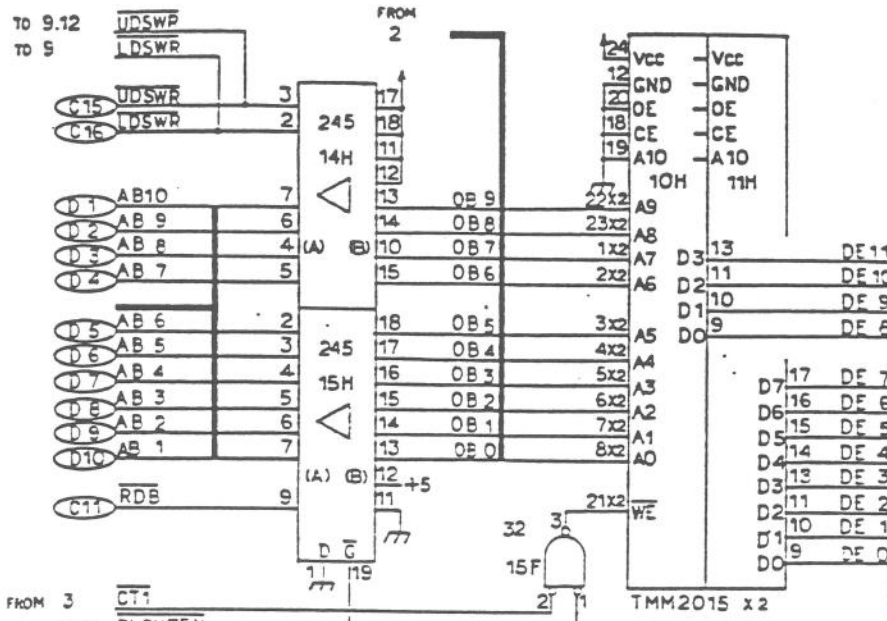

Sprite locations

DRAW NO.	86614	B	1	TITLE
DATE				
SCALE				
NTS				

@DOCTEURBOB
CAPCOM

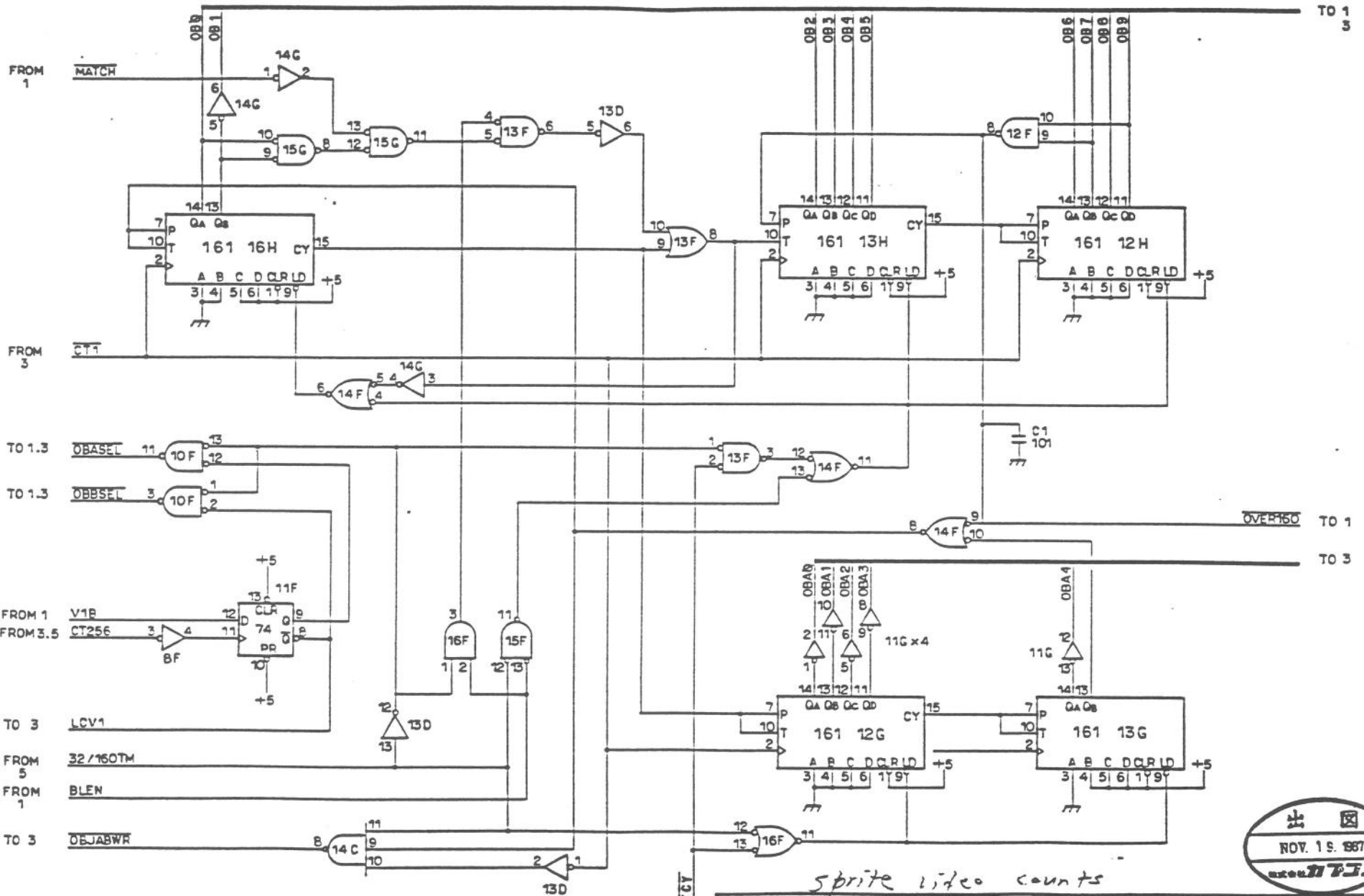

Sprite video counts



DRAW NO. 86614 B 2		TITLE	
DATE	DRAWN	CHECKED	DESIGNED / APPROVED
SCALE	@DOCTEUPHSE		CAPCOM
NTS	3RD	ANGLE	PROJECTION
			DIM IN SHEET

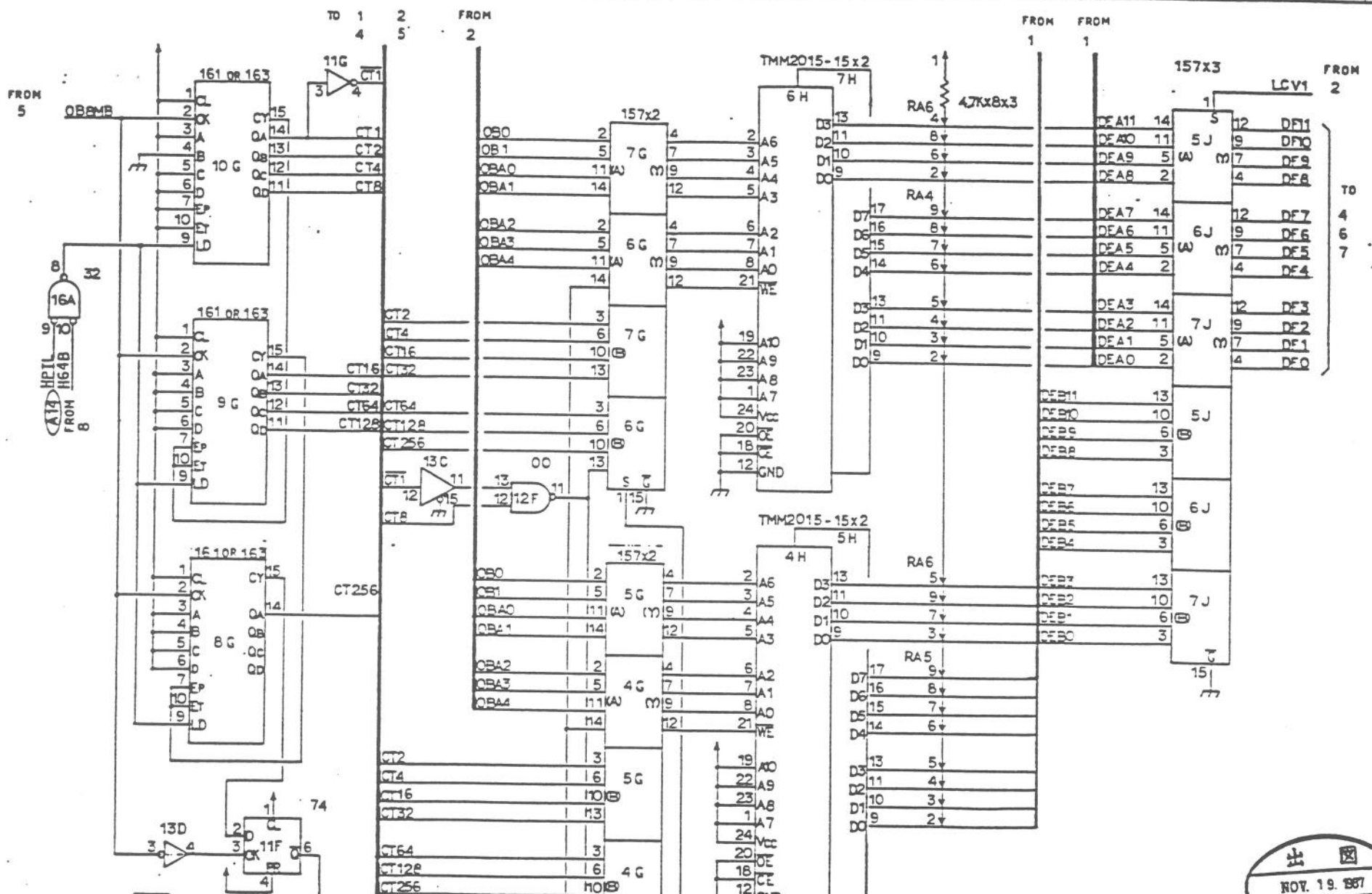

TO 2. CTCY
 FROM 2. OBJABWR
 FROM 2. OBSESEL
 FROM 2. OBASEL

Sprite fix (alt lines)

DRAW NO.	86614	B	3	TITLE
DATE		DRAWN CHECKED DESIGNED APPROVED		@DOCTEURPCB
SCALE	NTS			CAPCOM

3RD ANGLE PROJECTION DIM IN SHEET



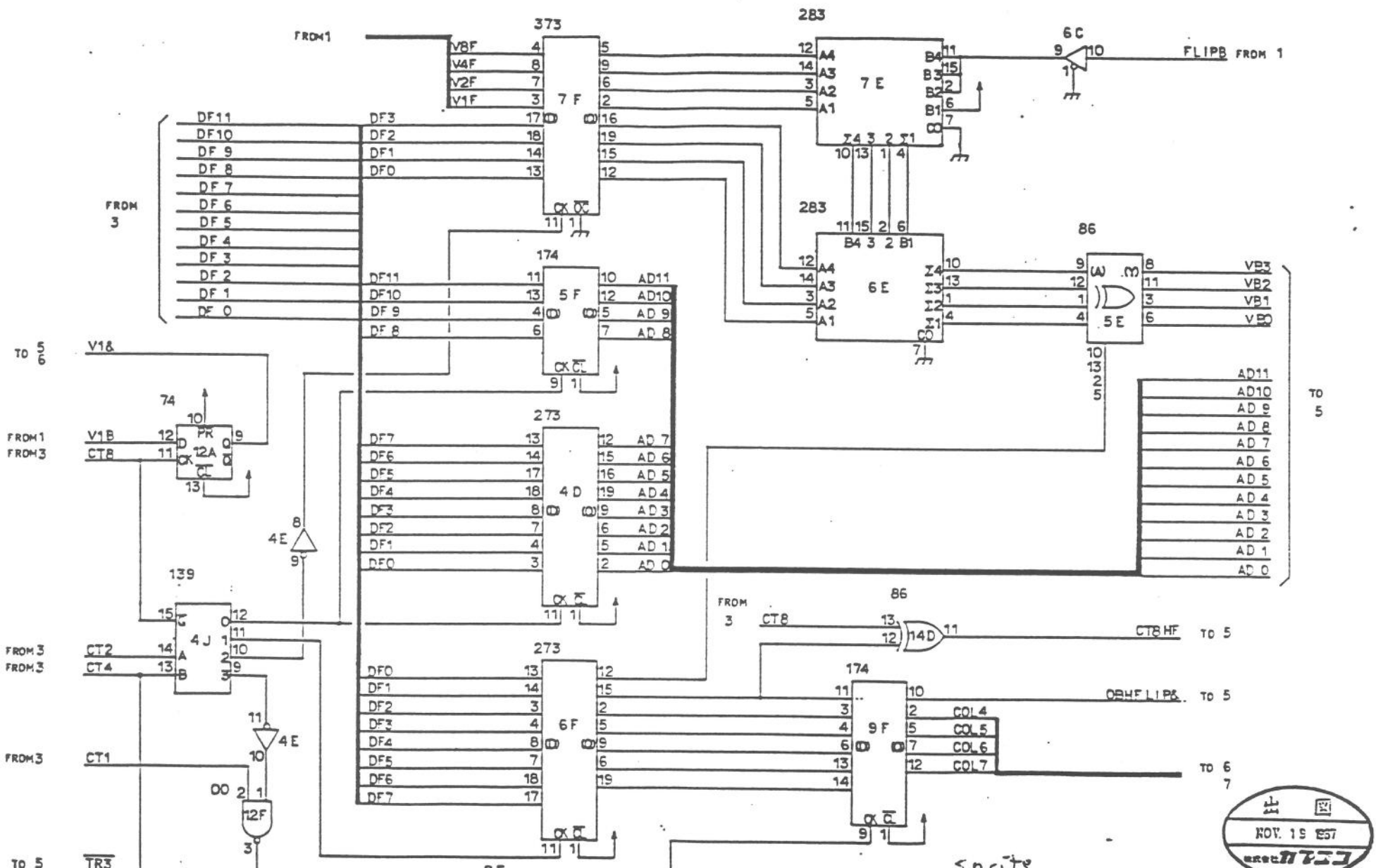

sprite

DRAW NO.		86614		B 4		TITLE	
DATE	DRAWN	CHECKED	DESIGNED	APPROVED	@DOCTEURPCB		
SCALE	NTS		3RD ANGLE		PROJECTION		DIM IN = 1 SHEET

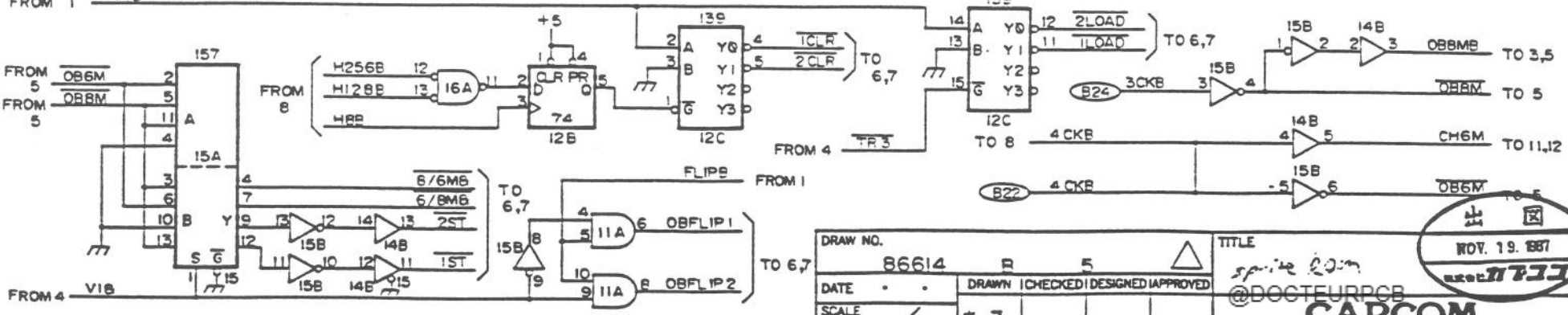
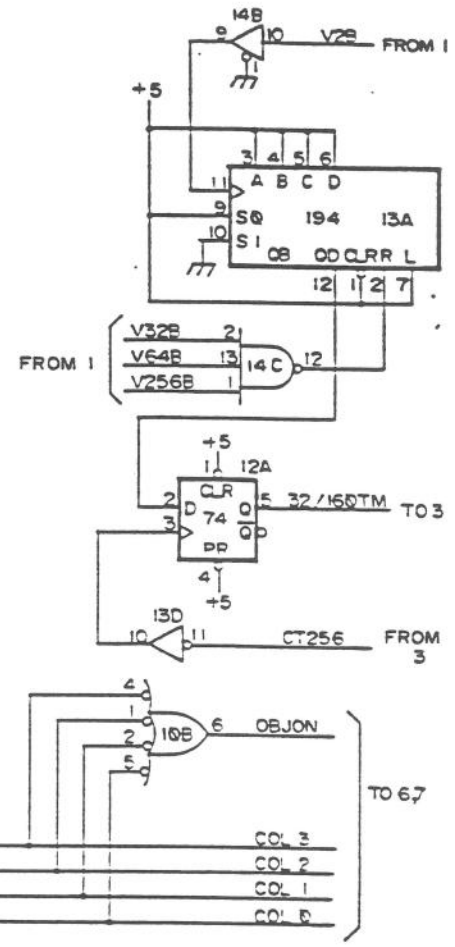
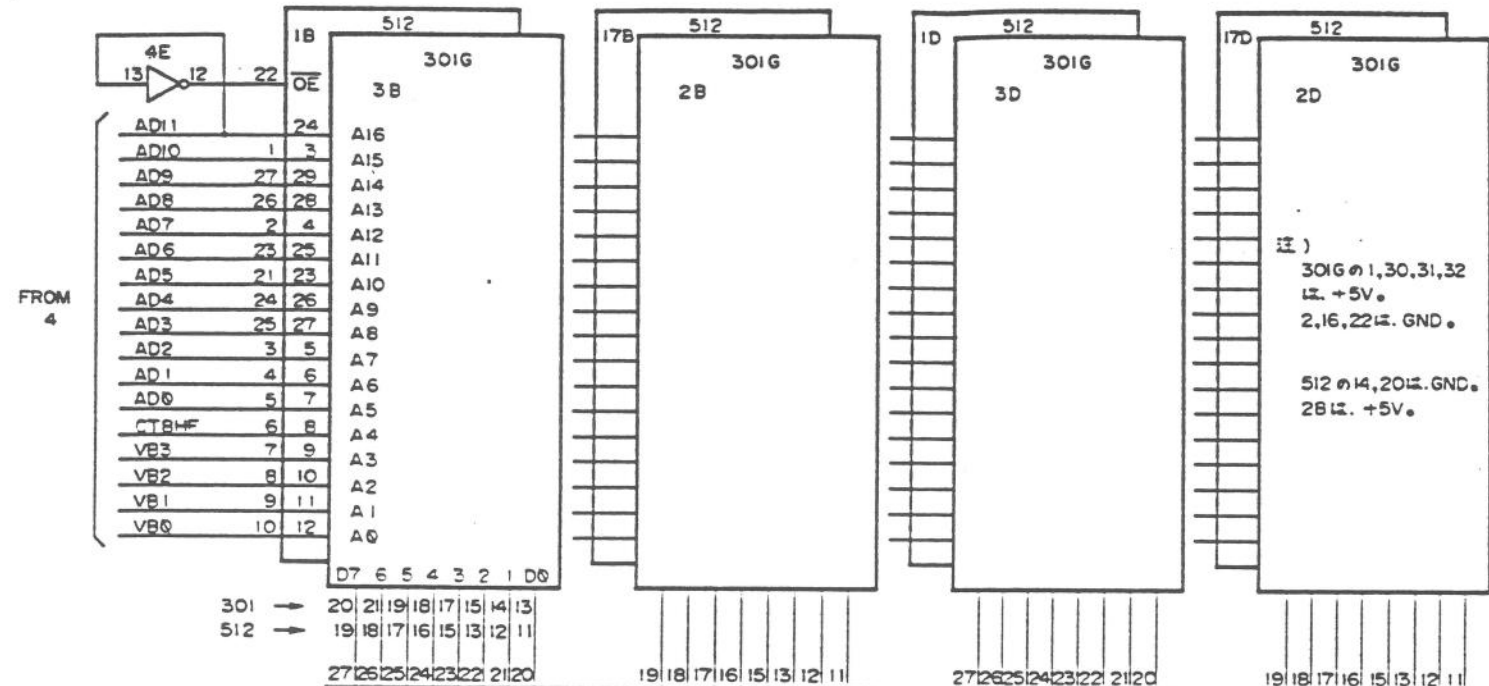

DRAW NO.		R 5		TITLE		NOV. 19. 1987	
DATE		DRAWN CHECKED DESIGNED APPROVED		spite 20m		CAPCOM	
SCALE NTS		3RD ANGLE PROJECTION		DIM IN		SHEET	



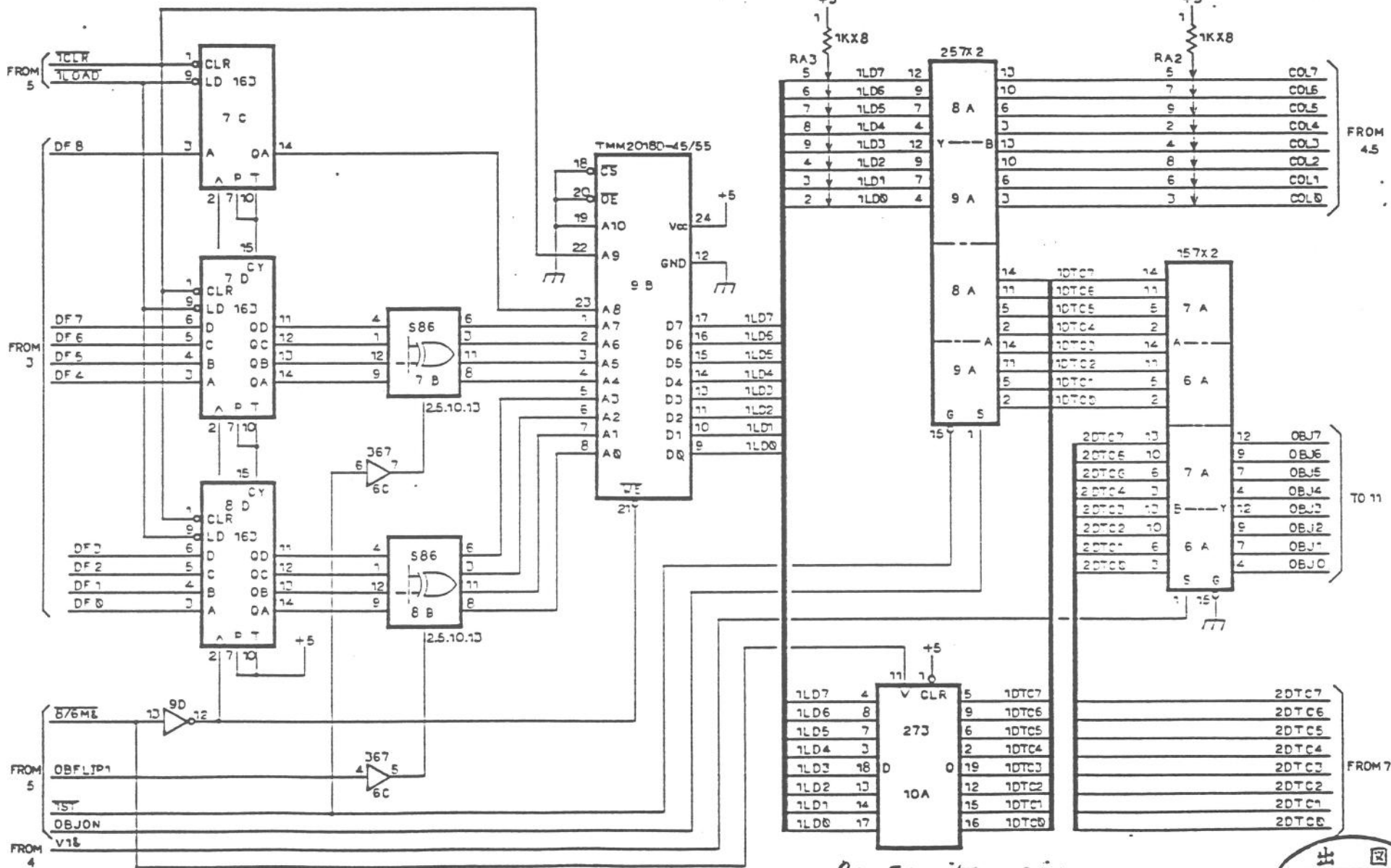

Pi Sprites pix



DRAW NO.		86614 B 6		TITLE	
DATE		DRAWN CHECKED DESIGNED APPROVED		@DOCTEURPCB	
SCALE		1:1		CAPCOM	
NTS		3RD ANGLE PROJECTION		DIM IN SHEET	

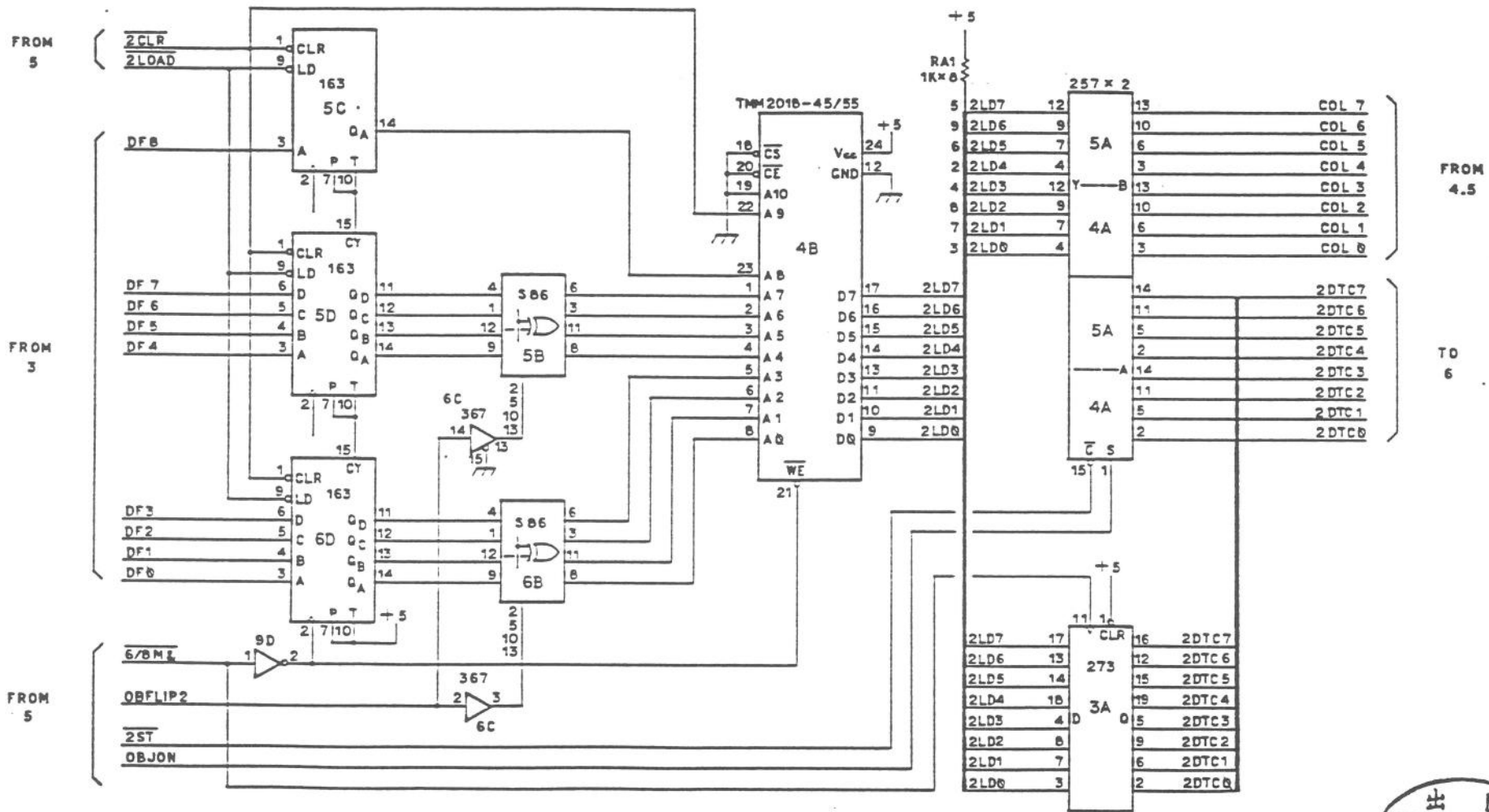

P2 Sprites Pix



DRAW NO. 86614 B 7		TITLE	
DATE	DRAWN CHECKED DESIGNED APPROVED		
SCALE	@DOCTEURPCB		
NTS	CAPCOM		
3RD	ANGLE	PROJECTION	DIM IN SHEET

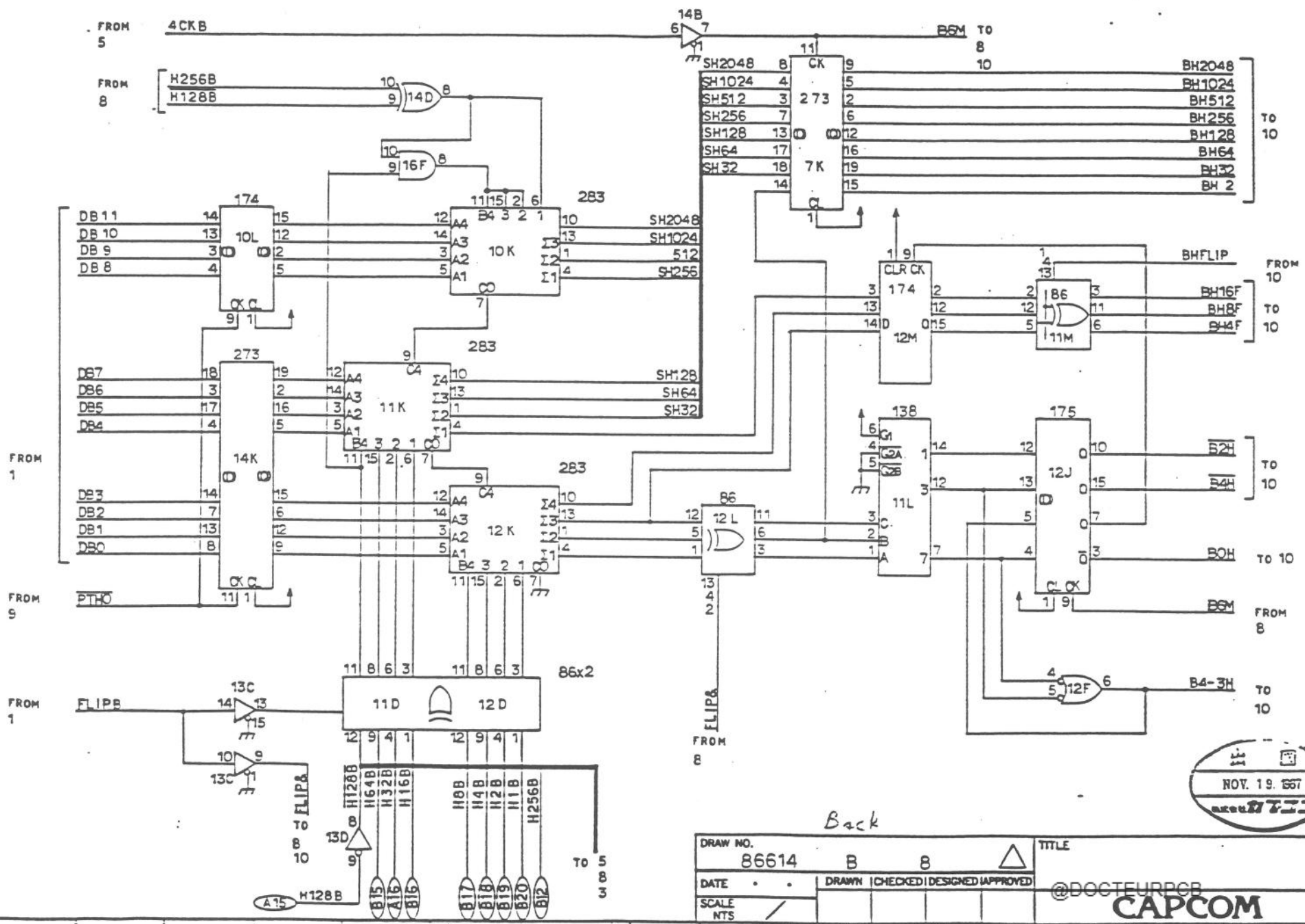

NOV. 19. 1987

Back

DRAW NO.		TITLE	
86614 B 8			
DATE	DRAWN	CHECKED	DESIGNED
SCALE	NTS		
3RD ANGLE PROJECTION		DIM IN SHEET	

@DOCTEURPCB
CAPCOM

CN-1-A		CN-1-B
VIDEO R	1	VIDEO R
VIDEO G	2	VIDEO G
VIDEO B	3	VIDEO B
GND	4	GND
CC 3	5	CC 2
CC 1	6	CC 0
CHAR Y	7	CHAR Z
GND	8	GND
V256B	9	V128B
V64B	10	V32B
V16B	11	V8B
V4B	12	V2B
V1B	13	GND
HPTL	14	H256B
H128B	15	H64B
H32B	16	H16B
COMPBLB	17	H8B
GND	18	H4B
GND	19	H2B
GND	20	H1B
GND	21	GND
GND	22	4CKE
GND	23	GND
GND	24	3CKE
GND	25	GND

CN-2-C		CN-2-D
GND	1	AB10
GND	2	AB9
GND	3	AB8
GND	4	AB7
VCC	5	AB6
VCC	6	AB5
VCC	7	AB4
VCC	8	AB3
VCC	9	AB2
COLRAM	10	AB1
RDB	11	RQB
FLIPB	12	AKB
SCRPT	13	BLCNTEN
ACL2	14	DB 11
UDSWR	15	DB 10
LDSWR	16	DB 9
VCC	17	DB 8
VCC	18	DB 7
VCC	19	DB 6
VCC	20	DB 5
VCC	21	DB 4
VCC	22	DB 3
VCC	23	DB 2
VCC	24	DB 1
VCC	25	DB 0



DRAW NO. 86614 CN-1.CN-2		TITLE 50P FLATCABLE CONNECTOR LIST	
DATE . . .	DRAWN CHECKED DESIGNED APPROVED		
SCALE NTS /	@DOC TEL POB CAPCOM		
3RD ANGLE PROJECTION		DIM IN = SHEET	

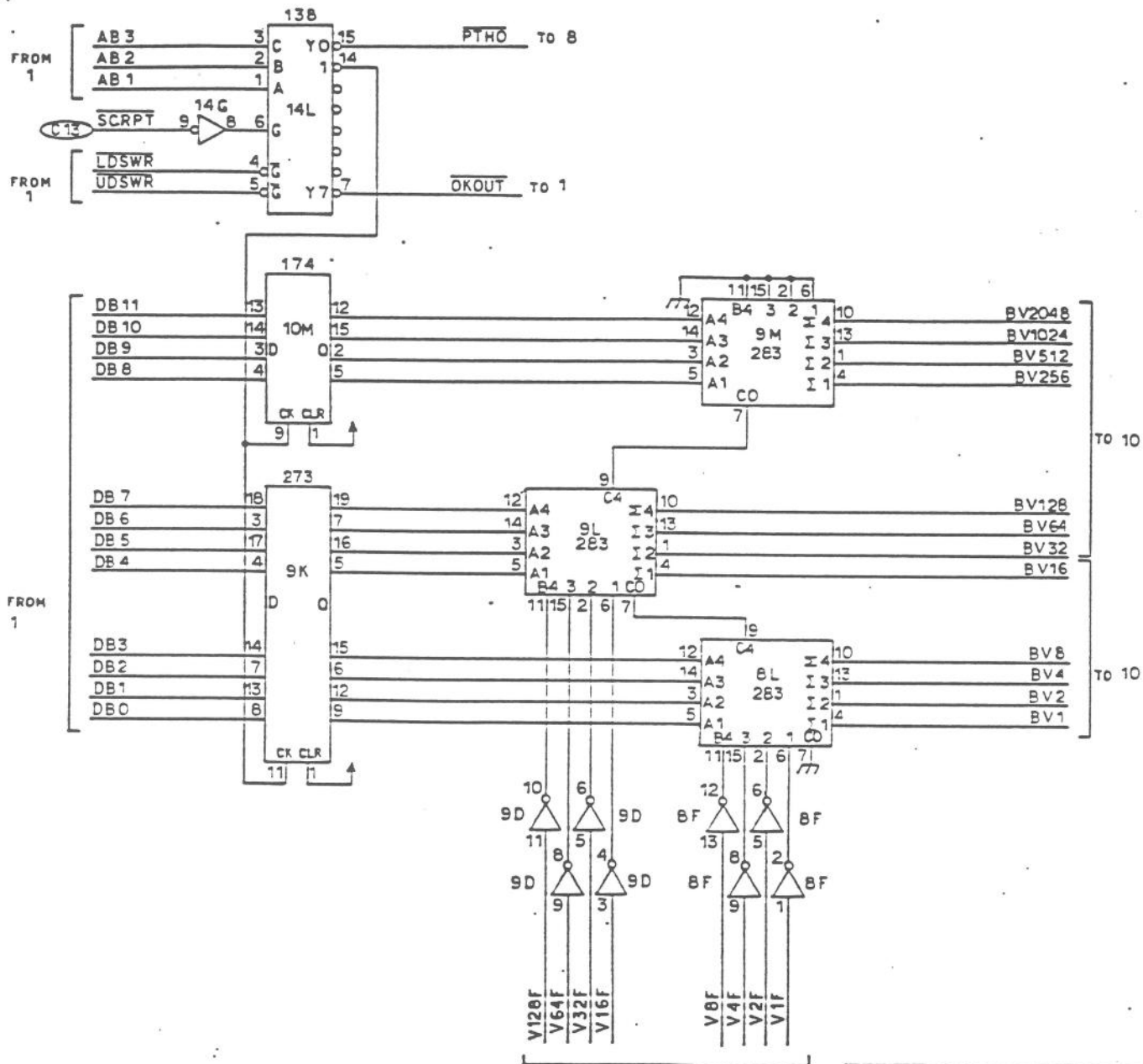

DRAW NO.		86614		B	9	TITLE	
DATE	• •	DRAWN		CHECKED	DESIGNED	APPROVED	@DOCTEURPCB
SCALE	NTS						CAPCOM

C25

BANC 0

BANC 0

FROM 8,9

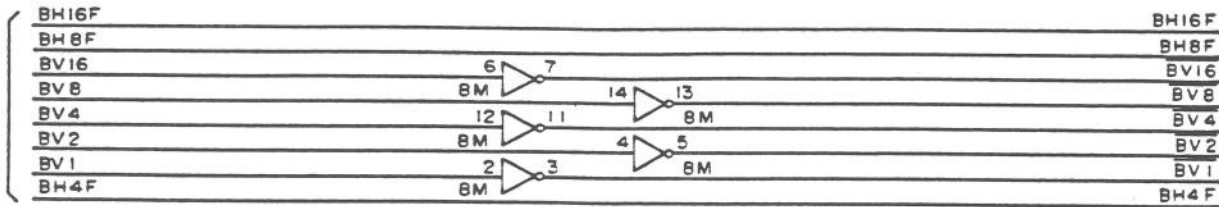

FROM 9

FROM 8

FROM 9

FROM 8

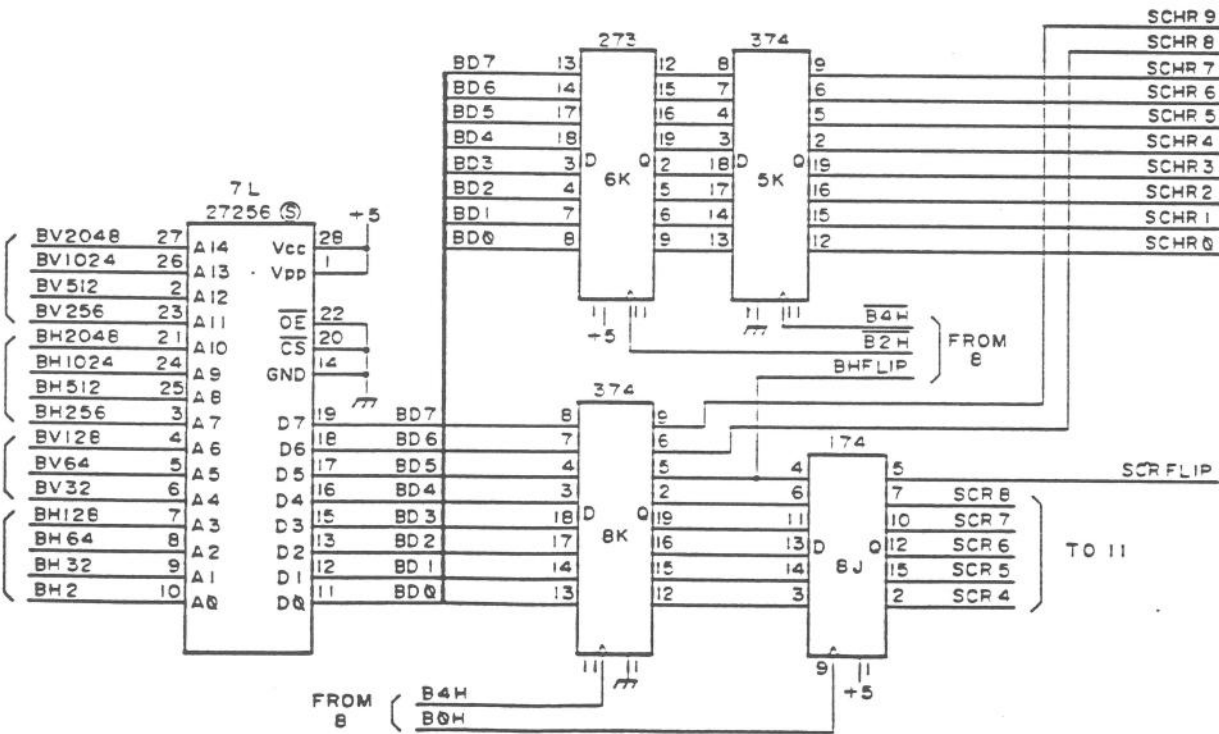

FROM 8

back location Table



DRAW NO. 87614-B-10		TITLE	back locations
DATE	DRAWN	CHECKED	DESIGNED
SCALE	NTS		@DOCTER
CAPCOM		SHEET	

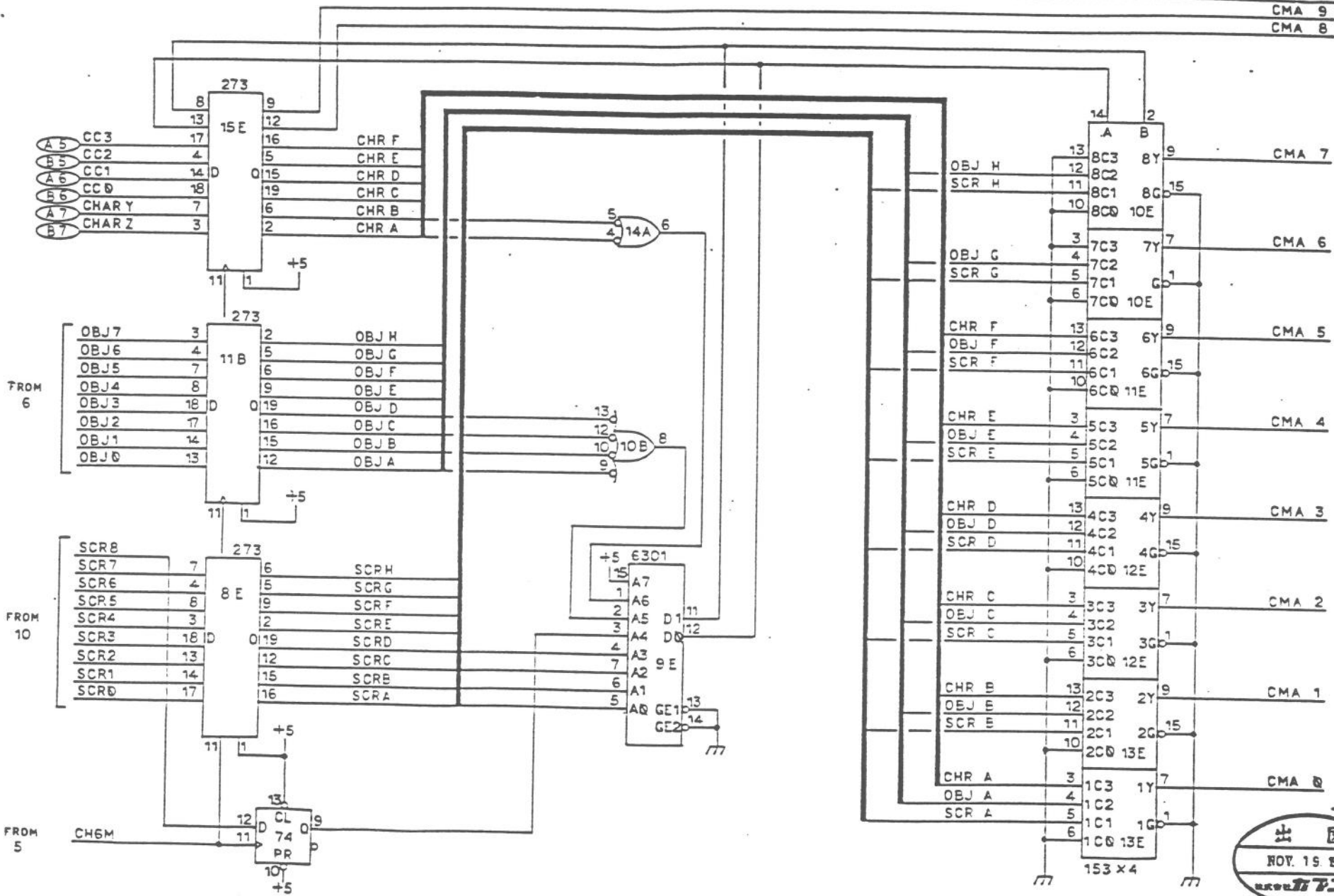

DRAW NO.		86614		B		11		TITLE		Color mix	
DATE		.		DRAWN		CHECKED		DESIGNED		APPROVED	
SCALE		NTS		3RD		ANGLE		PROJECTION		DIM IN = SHEET	

CAPCOM
 @DOCTEURPCB

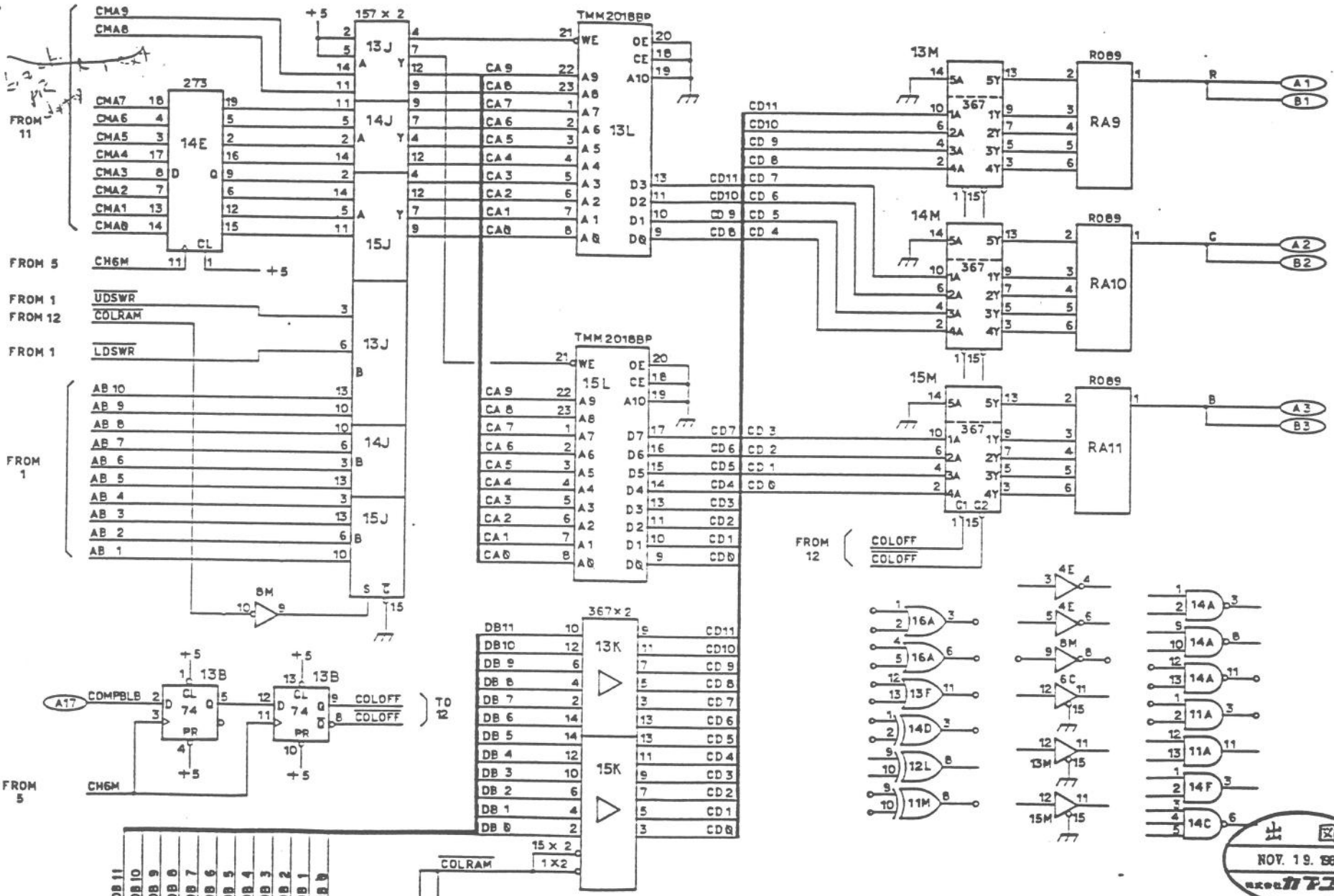



 NOV. 19. 1987

DRAW NO. 86614 B 12		TITLE TV output	
DATE	DRAWN / CHECKED / DESIGNED / APPROVED		
SCALE	@DOCTER/PCB		
NTS	CAPCOM		

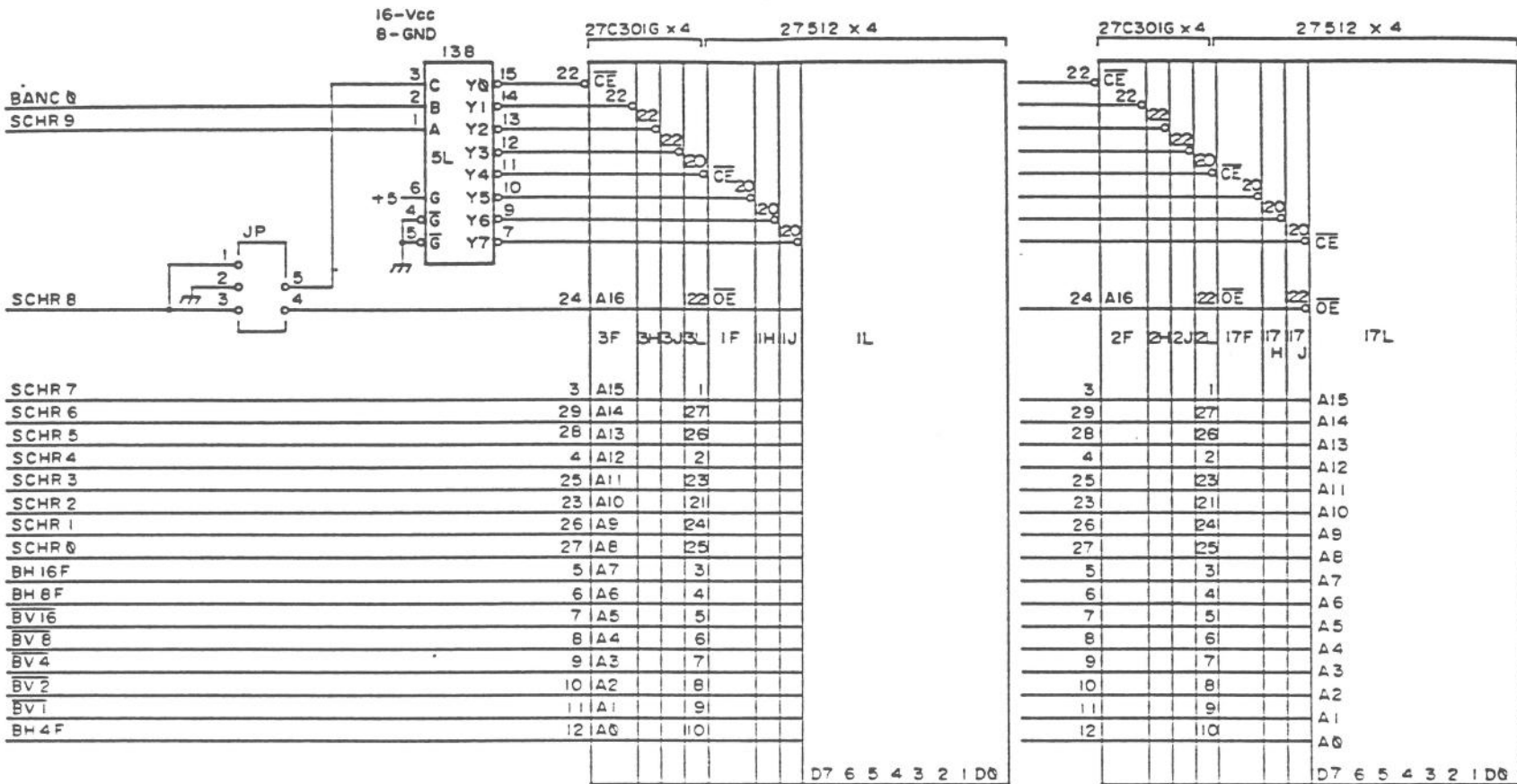
FROM 10

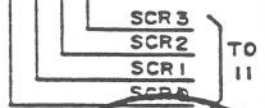
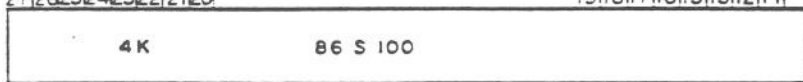
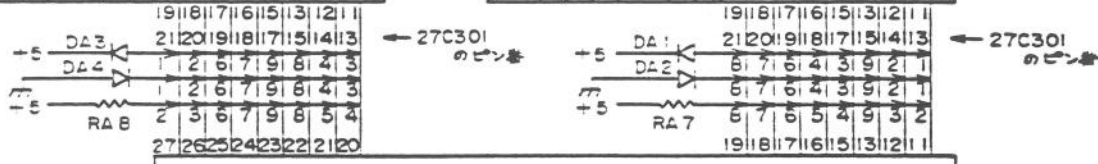

注) 27C301G x 8 の 32, 31, 30, 12 + 5 に接続
 2 16 は GND に接続
 27512 x 8 の 28 + 5 に接続
 14 は GND に接続



SCR FLIP

DRAW NO.		TITLE <i>L7-k</i>	
DATE	DRAWN	CHECKED	DESIGNED (APPROVED)
SCALE NTS	① ② ③ ④ ⑤ ⑥ ⑦ ⑧ ⑨ ⑩ ⑪ ⑫ ⑬ ⑭ ⑮ ⑯ ⑰ ⑱ ⑲ ⑳ ㉑ ㉒ ㉓ ㉔ ㉕ ㉖ ㉗ ㉘ ㉙ ㉚ ㉛ ㉜ ㉝ ㉞ ㉟ ㊱ ㊲ ㊳ ㊴ ㊵ ㊶ ㊷ ㊸ ㊹ ㊺		TO 11
CAPCOM		NOV. 15. 1987	

SOLDER SIDE				PARTS SIDE	
GND	A	1		GND	
GND	B	2		GND	
+5V	C	3		+5V	
+5V	D	4		+5V	
-5V	E	5		-5V	
+12V	F	6		+12V	
	H	7			
COIN COUNTER 2	J	8		COIN COUNTER 1	
COIN LOCK OUT 2	K	9		COIN LOCK OUT 1	
SP (-)	L	10		SP (+)	
N.C	M	11		N.C	
VIDEO GREEN	N	12		VIDEO RED	
VIDEO SYNC	P	13		VIDEC BLUE	
SERVICE SW	R	14		VIDEC GND	
TILT SW	S	15		TEST SW	
COIN SW 2	T	16		COIN SW 1	
START SW 2	U	17		START SW 1	
2P UP	V	18		1P UP	
2P DOWN	W	19		1P DOWN	
2P LEFT	X	20		1P LEFT	
2P RIGHT	Y	21		1P RIGHT	
2P PUSH 1	Z	22		1P PUSH 1	
2P PUSH 2	a	23		1P PUSH 2	
2P PUSH 3	b	24		1P PUSH 3	
N.C	c	25		N.C	
N.C	d	26		N.C	
GND	e	27		GND	
GND	f	28		GND	

PARTS NAME

CR7E-56DA-3.96E : (HIROSE)
OR
1168-056 -009 : (KEL)



DRAW NO.		TITLE	
		JANNA EDGE CONNECTOR	
DATE	DRAWN	CHECKED	DESIGNED
SCALE	@DOCTEUPDICE		
NTS	CAPCOM		
	3RD	ANGLE	PROJECTION
			DIM IN SHEET